

NON-LIFTABLE

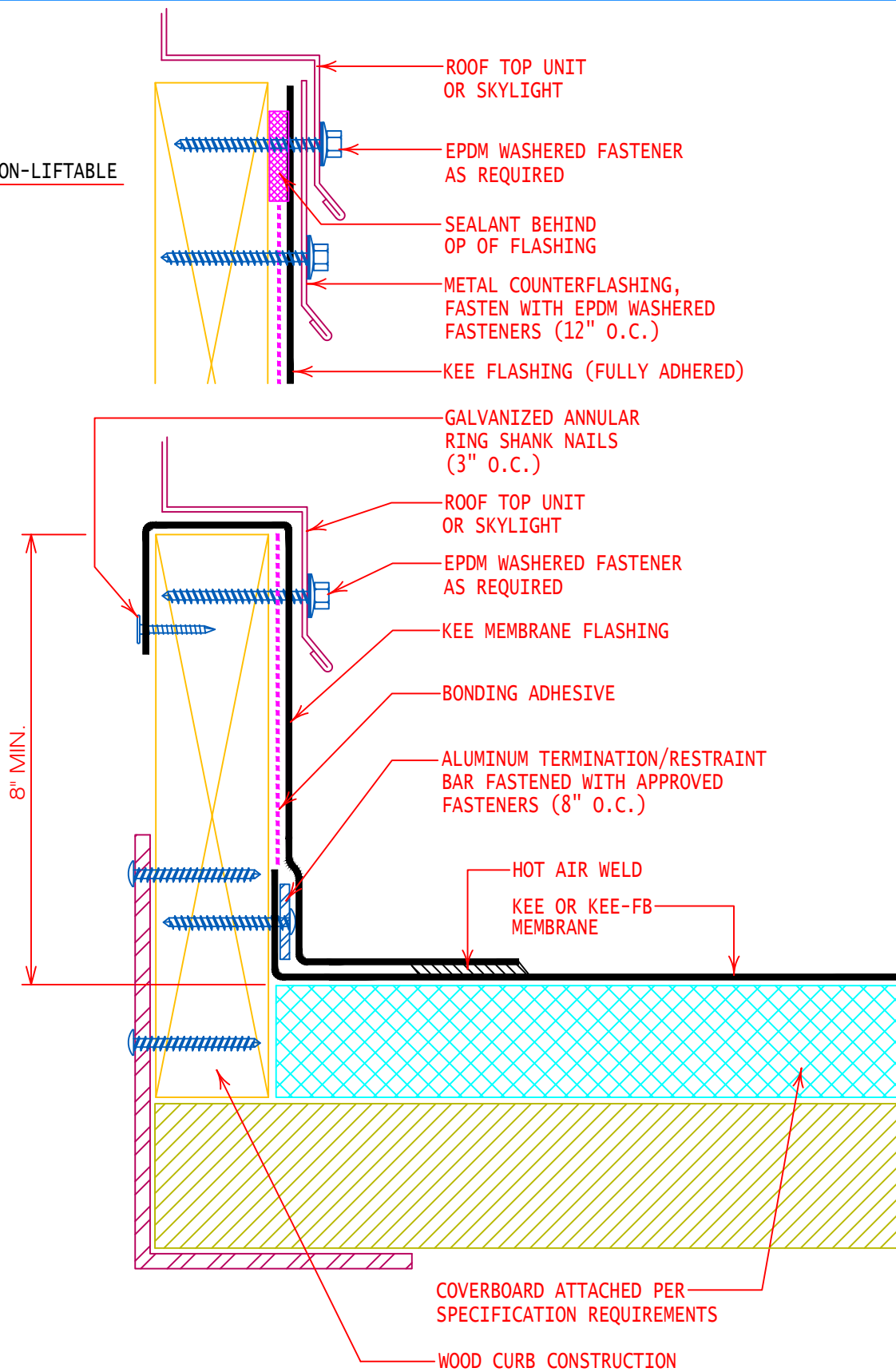

TYPICAL WOOD OR SKYLIGHT CURB FLASHING  
(BLOCKING ALTERNATE) T-BAR RESTRAINT

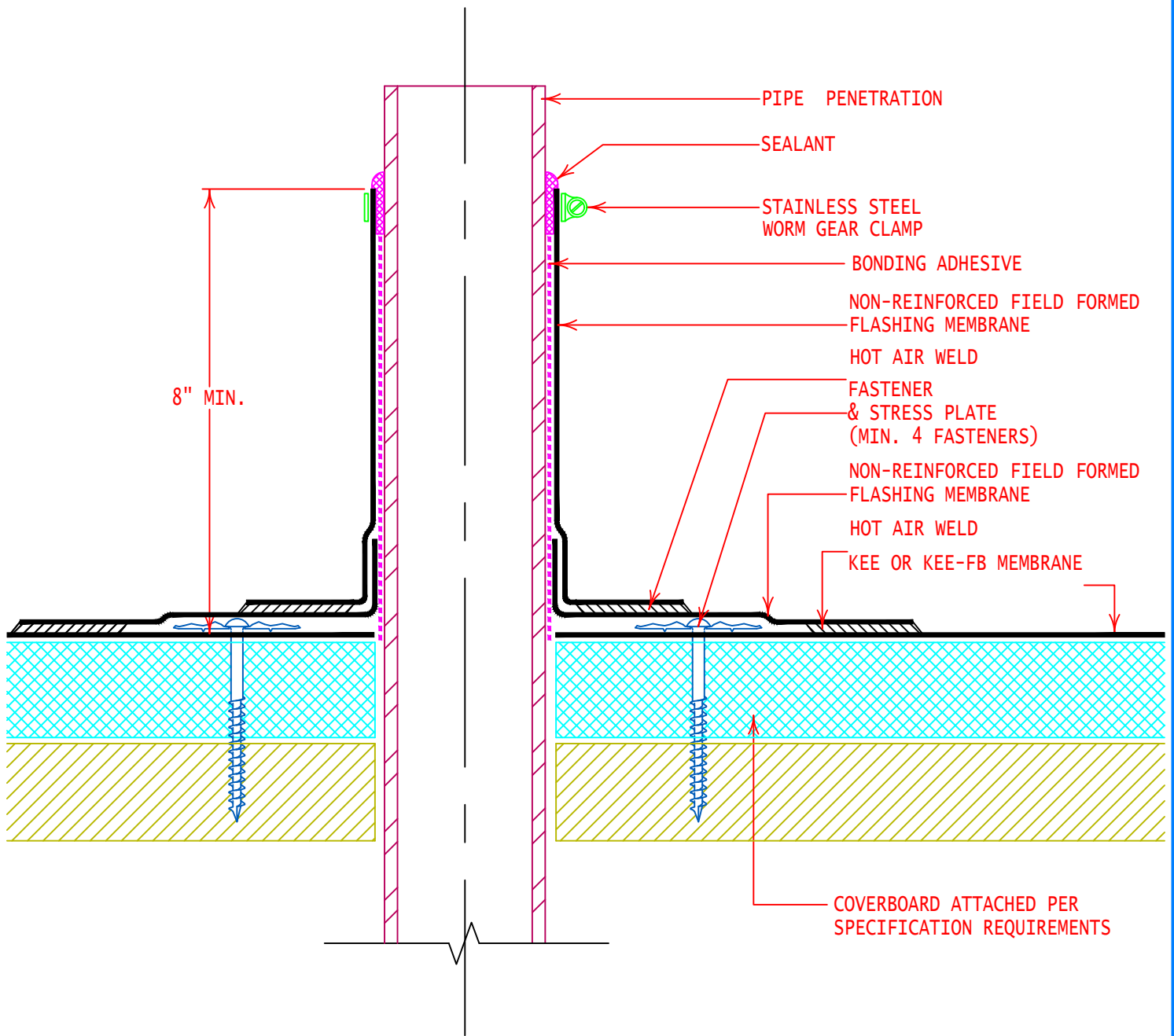

FIELD FABRICATED PIPE FLASHING

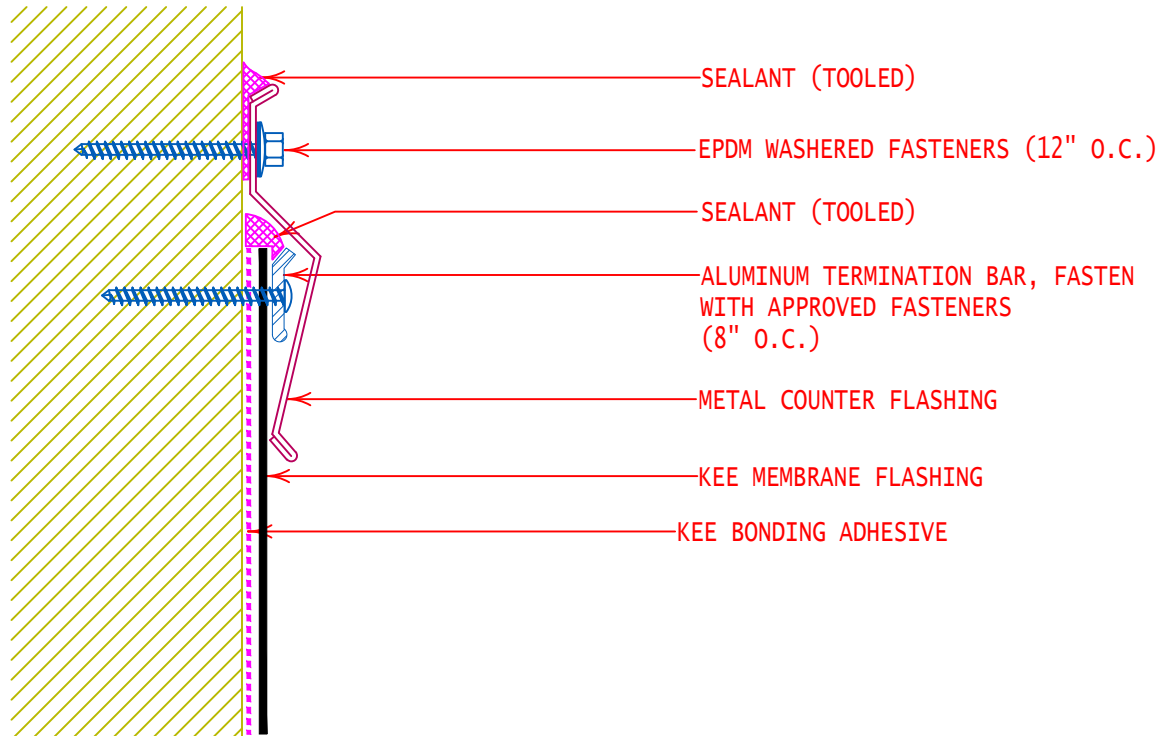

LOW WALL FLASHING

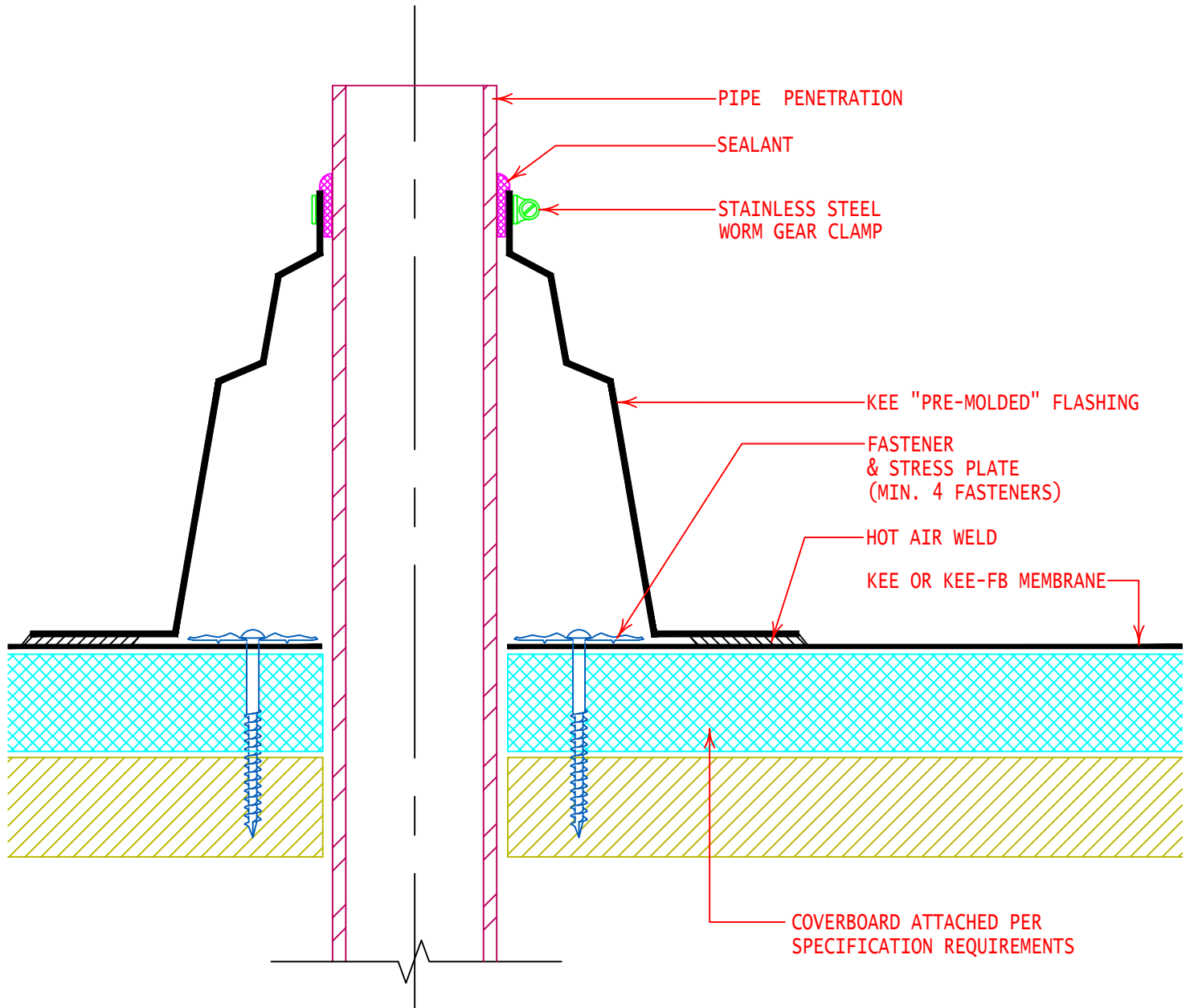

PRE-MOLDED PIPE FLASHING

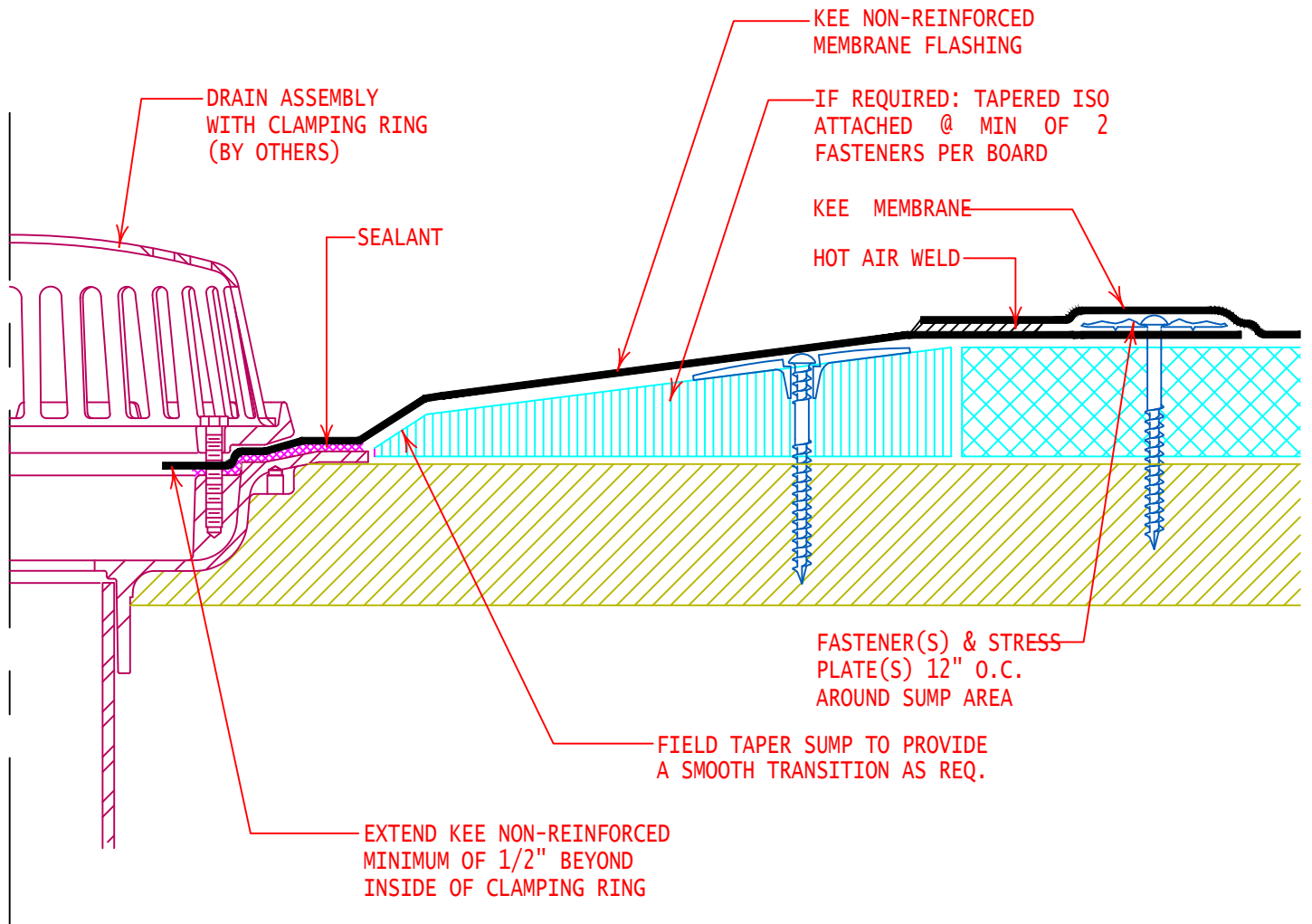

TYPICAL DRAIN FLASHING

	TYPICAL DRAIN FLASHING		

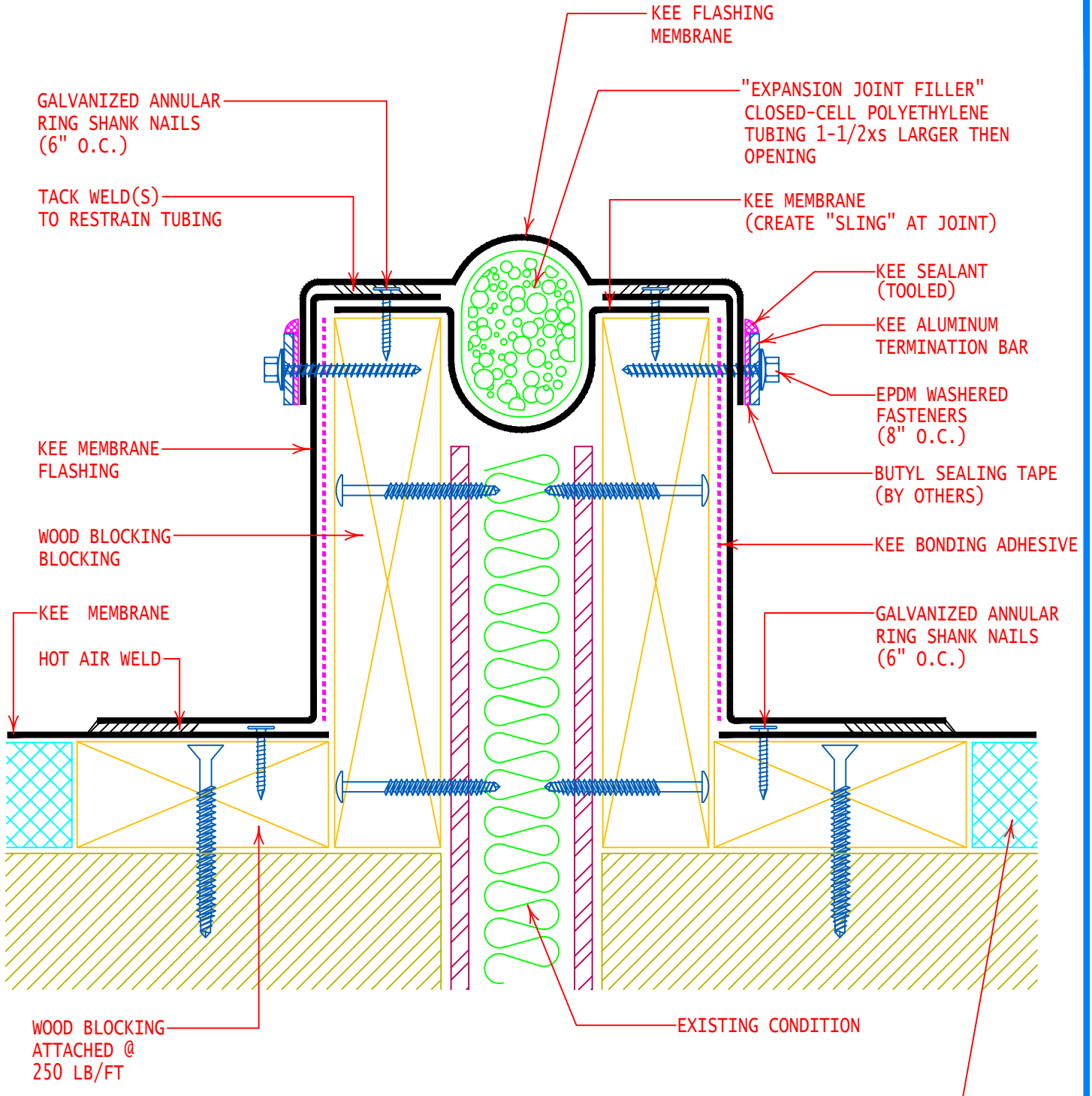

RAISED EXPANSION JOINT

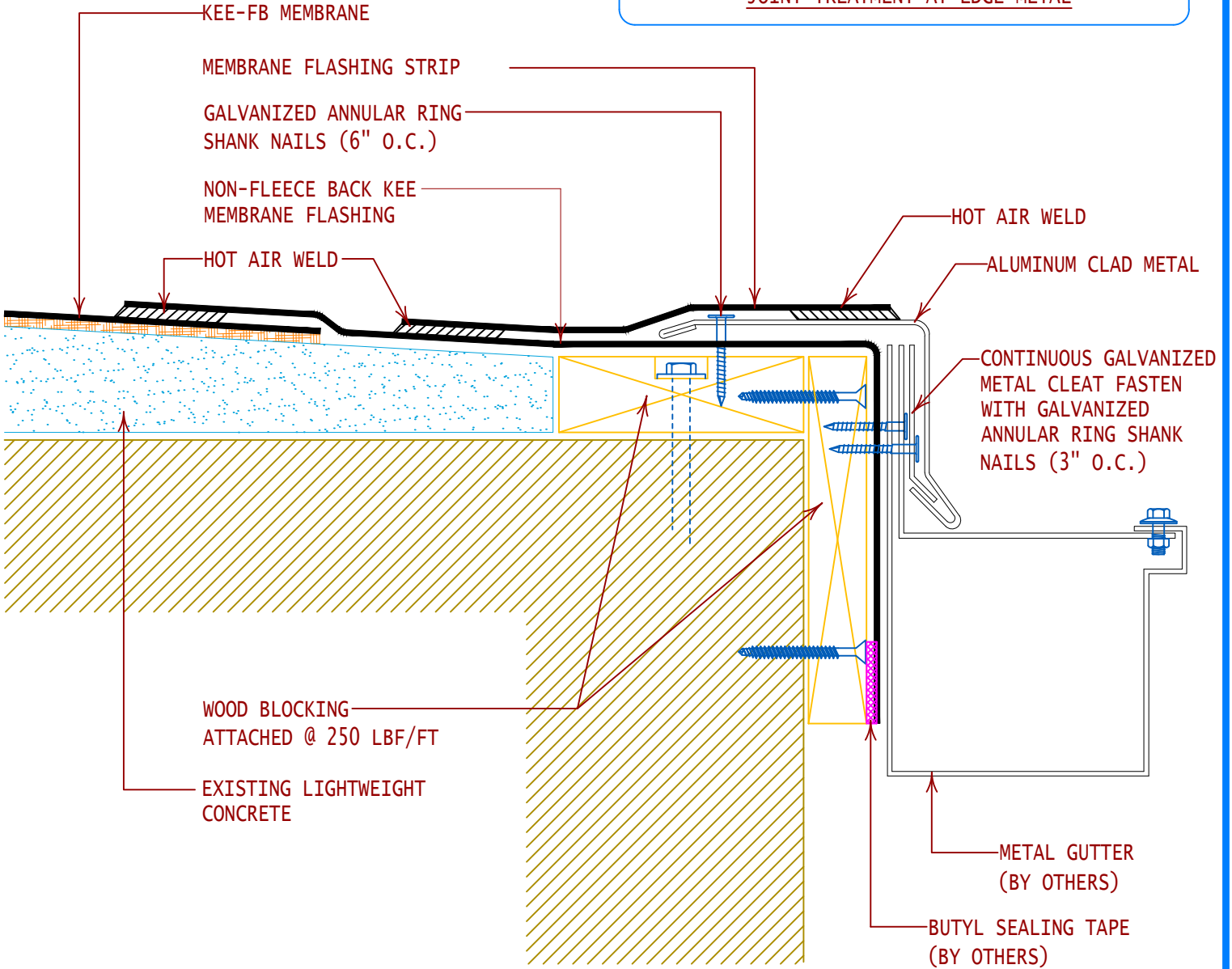
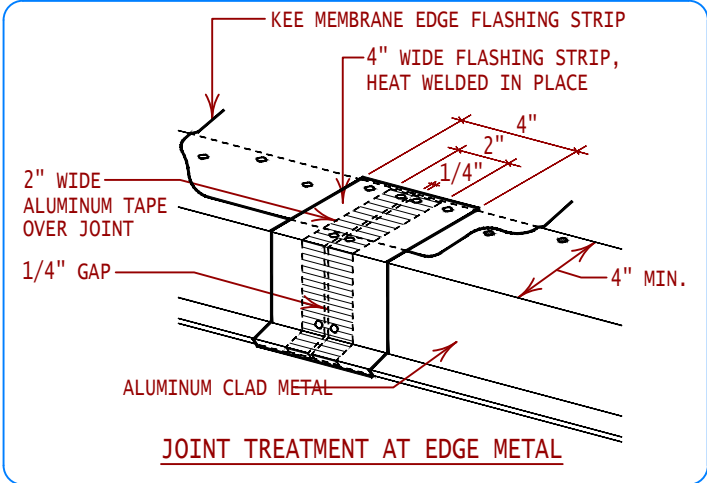

**GUTTER EDGE FLASHING  
LIGHTWEIGHT CONCRETE**