

Agenda Item Summary

1. ACTION REQUESTED/PURPOSE: Approve Project # PB070361, the utilization of the Florida Sheriff's Association Bid # 06-14-0821A for DOT/OPS for the purchase of two (2) Volvo 18 yard Dump Trucks at a price of \$118,496.54 each with a grand total of \$236,993.08 from General GMC Truck Sales and Service Inc. and one (1) Pot Hole Patch Truck at a price of \$120,380.00 from Sun State International Trucks. The cost breakdowns are as follows: Volvo 18 yd. Dump Trucks with a contract price of \$115,294.00, negotiated non-contract price of \$2,613.00 and a FSA Administrative Fee of \$589.54 for a grand total of \$118,496.54 each and a Pot Hole Patch Truck with a contract price of \$123,520.00 and non-contract option deduction of \$3,200.00 for a grand total of \$120,380.00. The Grand Total for all three vehicles is \$357,373.08.

2. FUNDING SOURCE: Fund - Transportation Trust Fund; Program - Roadway Maintenance

3. WHAT ACTION ACCOMPLISHES: Provides DOT/Operations with two new reliable dump trucks to support DOT crews, haul materials to and from job sites, stockpiling, ditch cleaning and various emergencies. The new pot hole patch truck enables DOT/Operations to pot hole patch and do various road repairs.

4. MANAGEMENT RECOMMENDATION: Approve

5. Departmental Category:

C9B

6. Meeting Date: APR 24 2007

- Consent
- Administrative
- Appeals
- Public
- Walk-On

- 8. Requirement/Purpose: (specify)**
- Statute
 - Ordinance
 - Admin. Code
 - Other

9. Request Initiated:
 Commissioner _____
 Department Transportation
 Division Operations
 By: Scott Gilbertson, Director

10. Background: On March 16, 2007, the Division of Purchasing received a request from Fleet Management/DOT Operations to piggyback the Florida Sheriff's Association Bid # 06-14-0821A to purchase two (2) Volvo 18yd. Dump Trucks from General GMC Truck Sales and Service Inc. and one (1) Pot Hole Patch Truck from Sun State International Trucks.

Account Strings: PC5410117500.506430

Attachments:

- (1) Department requests to Piggyback
- (2) Vendor Quotations/Florida Sheriff's Association Contract

11. Review for Scheduling:

Department Director	Purchasing or Contracts	Human Resources	Other	County Attorney	Budget Services				County Manager/P. W. Director
					Analyst	Risk	Grants	Mgr.	
<i>meurkap 4/2/07</i>	<i>Janet Sheehan 4.2.07</i>			<i>RS 4/6/07</i>	<i>RK 4/9</i>	<i>MR 4/9/07</i>	<i>4/9/07</i>	<i>4-5-07</i>	<i>4-5-07</i>

12. Commission Action:

- Approved
- Deferred
- Denied
- Other

REC'D by CO. ATTY. 4/16/07 3:50 PM
 CO. ATTY. FORWARDED TO: 4/16/07 4:50pm

RECEIVED BY COUNTY ADMIN: *PK*
 4-9-07
 8:30am
 COUNTY ADMIN FORWARDED TO: *PK*
 4-9-07
4/9/07



LEE COUNTY

DIVISION OF
FLEET MANAGEMENT

To: Janet Sheehan, Purchasing Director

From: Marilyn L. Rawlings, Fleet Manager *MLR*

Cc: Chris Jeffcoat, Brad Wright

Date: 3/16/07

Re: Volvo 18-Yard Dump Truck

2007 MAR 20 PM 2 15

Please prepare a Blue Sheet for the purchase of two Volvo 18-Yard Dump Trucks for the Department of Transportation, Operations Division.

ACTION REQUESTED:

Approve the Florida Sheriff's Contract (contract # 06-14-0821A) purchase of two (2) Volvo Dump Trucks Model-VHD64F200 for the Department of Transportation, Operations Division from General GMC Truck Sales and Service Inc. in the amount of \$118,496.54 for a total of \$236,993.08.

WHY ACTION IS NECESSARY:

Board approval is required, as this expenditure will exceed \$100,000.

WHAT ACTION ACCOMPLISHES:

This purchase will provide the Department of Transportation with two new reliable dump trucks that will be used to support all DOT crews, haul materials to and from job sites, stockpiling, ditch cleaning, and various emergencies.

MANAGEMENT RECOMMENDATIONS:

Approve this request to give the department two new Dump Trucks.

Funds for this purchase are available from account string # PC5410117500.506430.

BACKGROUND:

Lee County Fleet Management received a request from DOT/Operations to purchase two new Dump Trucks for new positions in their Operations Division/Road Construction. Road Construction currently has 2 smaller dump trucks. This contract expires September 30, 2007.



LEE COUNTY

DIVISION OF FLEET MANAGEMENT

2007 MAR 20 PM 2 14

To: Janet Sheehan, Purchasing Director
From: Marilyn L. Rawlings, Fleet Manager *MR*
Cc: Chris Jeffcoat, Brad Wright
Date: 3/16/2007
Re: Pot Hole Patch Truck

Please prepare a Blue Sheet for the purchase of one International , Model-4300, Pot Hole Patch Truck, for the Department of Transportation, Operations Division.

ACTION REQUESTED:

Approve the Florida Sheriff's Contract (contract # 06-14-0821A) purchase of one (1) Pot Hole Patch Truck, Model- 425-160 DHE, for the Department of Transportation, Operation Division from Sun State International Trucks, in the amount of \$120,380.

WHY ACTION IS NECESSARY:

Board approval is required, as this expenditure will exceed \$100,000.

WHAT ACTION ACCOMPLISHES:

This purchase will provide the Department of Transportation with a new reliable Pot Hole Patch Truck that will be used for pot hole patching and road surface repairs.

MANAGEMENT RECOMMENDATIONS:

Approve this request to give the department one new Pot Hole Patch Truck

Funds for this purchase are available from account string # PC5410117500.506430.

BACKGROUND:

Lee County Fleet Management received a request from DOT/Operations to purchase a new Pot Hole Patch Truck for new positions in their Operations Division. Lee County currently has 1 pot hole patch truck. Fleet has investigated purchasing options for this piece of equipment (i.e. Florida State Contract, Florida Sheriff's Bid, GSA etc.) and have concluded this is in the best interest of Lee County. This contract expires September 30, 2007.

Volvo Trucks North America

VHD64F200

**VOLVO & GMC TRUCKS OF PALM BEACH
360 S MILITARY TRL
WEST PALM BEACH, FL 33415-2808**

Prepared By : PETE BARBIS
561-686-8906
PBARBIS@HOTMAIL.COM

Prepared For : BRADLEY WRIGHT
LEE COUNTY

Tuesday, February 27, 2007 8:39:59 AM EST

Bradley S. Wright, CEM
 Operation Manager
 Lee County Fleet Management

CONTRACT PRICES

Base Price \$82,828.00
 Engine 405hp \$595.00
 64,000 lb. GVWR \$3,356.00
 Allison 4500RDS \$15,835.00
 18 yd. Dump body \$12,680.00

NON CONTRACT PRICES

Parts Manual (CD Rom) \$155.00 = cost (no discount)
 Service Manual (Print) \$450.00 = cost (no discount)
 AM/FM/CD \$510.00 = \$27.00 discount
 Pintle Hook \$390.00 = cost (no discount)
 Trl. Plug @ Rear \$75.00 (\$67 list + air to rear \$44)
 Trailer connections above List \$111.00 (\$36.00 discount)
 Hot Shift PTO/Auto. \$1000.00 = cost (no discount)
 Single 125 gal. Aluminum fuel tank \$33.00 List Price

Total Contract Price \$115,294.00 ea. ✓

Total Non Contract Price \$2,613.00 ea. ✓

FSA ADMINISTRATIVE FEE \$589.54 ea.

TOTAL PRICE \$118,496.54 each ✓

Price includes delivery to your location.

We look forward to being of service to the County of Lee.

Sincerely
 Pete Barbis, Territory Manager
 General GMC Truck Sales and Service
 dba Volvo Trucks of Palm Beach

Bradley S. Wright, CEM
Operation Manager
Lee County Fleet Management

CONTRACT PRICES

Base Price \$82,828.00
Engine 405hp \$595.00
64,000 lb. GVWR \$3,356.00
Allison 4500RDS \$15,835.00
18 yd. Dump body \$12,680.00

NON CONTRACT PRICES

Parts Manual (CD Rom) \$155.00
Service Manual (Print) \$450.00
AM/FM/CD \$510.00
Pintle Hook \$390.00
Trl. Plug @ Rear \$75.00
Hot Shift PTO/Auto. \$1000.00
Single 125 gal. Aluminum fuel tank \$33.00

Total Contract Price \$115,294.00

Total Non Contract Price \$2,613.00

FSA ADMINISTRATIVE FEE \$589.54

TOTAL PRICE \$118,496.54 each

Price includes delivery to your location.
We look forward to being of service to the County of Lee.

Sincerely
Pete Barbis, Territory Manager
General GMC Truck Sales and Service
dba Volvo Trucks of Palm Beach



Vehicle Specification

		Description
BASE MODEL		
004732	BASE MODEL	VHD64F200
VEHICLE ADAPTATION		
S 114010	MARKET ADAPTATION	USA/USA TERRITORY MARKET ADAPTATION
S 125001	AREA/DOMICILE (EXHAUST)	49 STATE/NON CALIFORNIA
O DKG2	GROSS COMBINATION WEIGHT	80,000 LB GROSS COMBINATION WEIGHT
S 259003	VEHICLE VOCATION	CONSTRUCTION SERVICE
S 260003	OPERATING CONDITIONS	MOUNTAINOUS/ Q UARRY, STARTING GRADES<20%
S 261006	WEIGHT CLASS	GVW 53,001-63,000# (24-28 METRIC TONS)
S 262001	ADDITIONAL AXLE CONFIGURATION	NO ADDITIONAL PUSHER OR TAG AXLES
S 263217	VEHICLE APPLICATION	TRUCK VOC/STOCK, UNIDENTIFIED END USER
S DH30	OPERATING CLASS	OPERATING CLASS THREE (CONSTRUCTION)
S FHL1	VEHICLE WIDTH	102" (2590 MM) VEHICLE WIDTH
CAB		
S 2CD3	CAB TYPE	HSS DAY CAB W/B-PILLAR DEPRESSION
HOOD		
S CD23	HOOD TYPE	CONSTRUCTION HOOD LENGTH
ENGINE		
X 1017B0	ENGINE PACKAGE	VOLVO D13 405 HP 2100 GOV RPM 1450 LB-FT @ 1100 RPM - '07 ENGINE EMISSION LEVEL
ENGINE EQUIPMENT		
S 94AA1X	FAULT CODE DISPLAY FILTER	FAULT CODE DISPLAY FILTER
S 0NAA1X	OPTIMIZED FUEL ECON INDICATOR	PERFORMANCE BONUS GUIDE - ENGINE SWEET SPOT GAUGE
S K5A2	ENGINE PROTECTION SYSTEM	ENGINE PROTECTION (SHUTDOWN)
S K7A1	ENGINE IDLE CONTROL	BASIC ENGINE IDLE CONTROL
S 220069	AIR CLEANER PACKAGE	SINGLE STAGE AIR CLEANER DRY TYPE WITH DUAL SIDE AIR INTAKE
S JWD1	AIR INTAKE	HOOD MOUNTED AIR INTAKE GRILLE
O H9K1	RADIATOR	1240 SQ IN, 2 ROW CORE RADIATOR



O K909	COOLANT	EXTENDED LIFE ANTIFREEZE -34 F (-37 C)
O C4A2	COOLANT MANUFACTURER	CHEVRON TEXACO
O 208021	FAN CLUTCH PACKAGE	KYSOR ON/OFF FAN CLUTCH
S NCD1	STARTER	VOLVO 12V GEAR REDUCTION STARTER (MODEL 105P55)
S PJCK	ALTERNATOR	DELCO REMY 12 V 110 AMP 34SI PAD MOUNT ALTERNATOR
O 810113	BATTERY PACKAGE	3 VOLVO MAINTENANCE FREE 12VOLT 2280CCA BATTERIES
S 230019	EXHAUST SYSTEM	COMPACT DPF MTD RHS UNDER CAB W/ VERT PIPE
S 232088	EXHAUST STACK PACKAGE	10' 0" ALUMINIZED STAINLESS STEEL SINGLE STACK
S K0C4	EXHAUST FEATURES	STRAIGHT STACK, SIDE OUTLET DIFFUSER BOX
S DVC3	LOWER EXHAUST PIPING	ALUMINIZED STAINLESS STEEL EXHAUST PIPE
S CUB1	EXHAUST PIPING FLEX SECTION	STAINLESS STEEL EXHAUST FLEX SECTION
S KNC1	EXHAUST SHIELD	ALUMINUM EXHAUST SHIELD
S JVH1	PRIMARY FUEL FILTER	VOLVO 30 MICRON FUEL FILTER
S J3A3	SECONDARY FUEL FILTER	DUAL ENGINE MOUNTED FUEL FILTER WITH WATER SEPARATOR
S VWCA	COMPRESSOR	WABCO 31.8 CFM COMPRESSOR
S HTH1	ENGINE BRAKE	VOLVO VARIABLE GEOMETRY TURBO BRAKE
S 103005	ENGINE OIL CHECK & FILL	ENGINE MOUNTED-SIDE FILL TUBE
S QHC1	ENGINE OIL PAN	STAMPED STEEL OIL PAN (STANDARD OIL CHANGE INTERVALS)

TRANSMISSION

O RWB0	TRANSMISSION PACKAGE	ALLISON 4500 SERIES 6 SPEED WITH PTO PROVISION
O RSAC	ALLISON TRANSMISSION ELECTRONICS	CONSTRUCTION RDS GROUP 100 PACKAGE 146
S D4AZ1X	AMT PTO FUNCTIONS	WITHOUT AMT PTO FUNCTIONS
O 7RB1	TRANSMISSION LUBRICANT	SYNTHETIC TRANSMISSION LUBRICANT
O T2D1	TRANSMISSION COOLER	WATER TO OIL COOLER, ALLISON TRANS
O 258037	TRANSMISSION VOCATION CODE	STRAIGHT TRUCK ON-HIGHWAY/NO PLOW
S TKA1	DRIVELINE	CALCULATED TO TORQUE REQUIREMENTS
S THC2	DRIVELINE MANUFACTURER	SPICER LIFE DRIVELINE WITH XL U-JOINTS

FRONT AXLE



O 370361	FRONT AXLE PACKAGE	VOLVO VF20 18.8K FRONT SPRINGS W/ UNITIZED HUBS
O U5B1	FRONT BRAKE DIMENSION	16.5X6 FRONT BRAKE SIZE
S UDA1	FRONT AXLE BRAKE DUST SHIELD	FRONT BRAKE DUST SHIELDS
S XABF	POWER STEERING GEAR	TRW THP60 INTEGRAL POWER STEERING GEAR
S M0A1	STEERING SHAFT TYPE	BASIC STEERING SHAFT
S I9A1	STEERING LINKAGE	SEALED DRAG LINK
O XEA1	POWER STEERING ASSIST	RIGHT HAND RAM ASSIST
O 371072	FRONT SUSPENSION PACKAGE	MULTILEAF FRONT SUSPENSION
S IRA1	SPRING MAINTENANCE TYPE	LUBRICATED SPRING PINS AND BUSHINGS
O 0KG1	HUBS, FRONT AXLE	IRON UNITIZED FRONT AXLE HUBS
S U3A1	BRAKE DRUM, FRONT AXLE	CAST IRON FRONT BRAKE DRUM OUTBOARD MOUNTED
O K4AD1X	WHEEL NUT TYPE, FRONT	LOCK SNAP RING W/ LOCK TAB FRONT SPINDLE NUTS - UNITIZED ONLY
O ZGC1	FRONT OIL SEAL CAP	UNITIZED FRONT AXLE OIL SEAL CAP
S 373001	FRONT SHOCK ABSORBER	FRONT SHOCK ABSORBERS
S 7VB1	FRONT AXLE LUBRICANT	SYNTHETIC FRONT AXLE LUBRICANT

REAR AXLE

O 330444	REAR AXLE PACKAGE	ARVIN MERITOR RT46-160 46,000 LB CAPACITY
O TAJA	REAR AXLE RATIO	4.56 REAR AXLE RATIO
S TUB1	DIFFERENTIAL LOCK	INTERAXLE DIFFERENTIAL LOCK
S 0LE1	HUBS, DRIVE AXLE	IRON PRESET DRIVE AXLE HUB
S N2AA1X	WHEEL NUT TYPE, REAR	LOCK TAB DRIVE SPINDLE NUTS
S 1CA2	OIL SEALS, DRIVE AXLE	CHICAGO RAWHIDE PLUS XL DRIVE OIL SEALS
S U4A1	BRAKE DRUM, DRIVE AXLE	CAST IRON DRIVE AXLE BRAKE DRUM OUTBOARD MOUNTED
S 7WAD	REAR AXLE LUBRICANT	CHEVRON DELO GEAR LUBRICANT ESI SAE 80W-90 (APPROVED FOR EXTENDED COMPONENT WARRANTY)
O 350380	REAR SUSPENSION PACKAGE	46K VOLVO T-RIDE (3-LEAF) 54" SPACING
S ULH2	WHEEL BRAKE TYPE FRONT AND REAR	ARVIN MERITOR Q+ CAST FRONT, Q+ CAST REAR
S U8A1	DRIVE AXLE BRAKE DIMENSION	16.5X7 REAR BRAKE SIZE
S UEA1	DRIVE AXLE BRAKE DUST SHIELD	REAR BRAKE DUST SHIELDS
S VCA1	SLACK ADJUSTER VENDOR FRONT AND REAR	GUNITE AUTOMATIC SLACK ADJUSTER FRONT AND REAR



S WRA1	ANTILOCK BRAKE SYSTEM MANUFACTURER	BENDIX ABS
S 781056	PARKING BRAKE CHAMBER PACKAGE	FOUR CAM TYPE HALDEX
S UKA1	CHAMBER STROKE LENGTH, FRONT AND REAR	BASIC LENGTH BRAKE CHAMBER STROKE

CHASSIS

O 400222	WHEELBASE	222" WHEELBASE
S X499	FRONT FRAME EXTENSION	NO FRONT FRAME EXTENSION PROVIDED
O 403011	FRAME RAIL PACKAGE	11.81"X4.13"X.44" STRAIGHT STEEL RAILS
S 8EB1	INTERMEDIATE CROSSMEMBER MATERIAL	STEEL CROSSMEMBER MATERIAL
S OAA1	INTERMEDIATE CROSSMEMBER CONFIGURATION	BASIC INTERMEDIATE CROSSMEMBER
S X8B1	FORWARD REAR SUSP CROSSMEMBER MATERIAL	STEEL CROSSMEMBER MATERIAL
S ZIA1	BOGIE CROSSMEMBER MATERIAL	STEEL CROSSMEMBER MATERIAL
S 402055	OVERHANG	55" OVERHANG
S X6A1	REAR FRAME TREATMENT	STRAIGHT CUT-OFF REAR CROSSMEMBER
S VHD8	AIR DRYER	MERITOR WABCO 1200UP AIR DRYER WITH HEATER AND WITHOUT TURBO CUT OFF VALVE
S U2B1	AIR TANKS	STEEL AIR TANKS
S UWB1	AIR TANK DRAIN VALVE	MANUAL PULL CORD ON ALL AIR TANKS
S 6B99	FIFTH WHEEL LOCATION	NO FIFTH WHEEL POSITION PROVIDED
O 424088	FUEL TANK PACKAGE	SINGLE 125 GAL LH 26 DIA UNPTD ALUM
S HBB1	FUEL TANK POSITION	FUEL TANK POSITION 1
S JHA1	FUEL LINES	NYLON FUEL LINES
S KHA1	FUEL TANK STRAPS	PAINTED STEEL FUEL TANK STRAPS
S KFA1	FUEL TANK CAP	NON-LOCKING FUEL TANK CAP
O WHC1	TRAILER BRAKE CONNECTION POSITION	TRAILER CONNECTIONS MTD END OF FRAME
S WK99	HOSE TENDER POSITION	NO HOSE TENDER POSITION PROVIDED
S L0A1	ELECTRICAL JUNCTION BOX BACK OF CAB	BODY BUILDER JUNCTION BOX BACK OF CAB
O L2A1	ELECTRICAL RECEPTACLE END OF FRAME	ELECTRICAL RECEPTACLE END OF FRAME
S WLC1	TRAILER BRAKE HAND CONTROL	DELETE TRAILER BRAKE HAND CONTROL
O 5RA1	BACKUP ALARM	ELECTRIC BACKUP ALARM



S L416	BATTERY BOX MOUNTING	BATTERY BOX, LHS, BEHIND FRONT FENDER
S L5A1	BATTERY BOX COVER	BASIC BATTERY BOX COVER
S NQB1	BATTERY BOX CONFIGURATION	BATTERY BOX - 3 CAPACITY
S 4DE3	FRONT BUMPER	STEEL CONSTRUCTION BUMPER-THREE PIECE
O FRB1	BUMPER POSITION	BUMPER EXTENDED 2" AHEAD OF STANDARD POSITION
O 65A1	FRONT FENDER EXTENSION	WITH FRONT FENDER EXTENSION
S 4EB1	FRONT TOWING DEVICE	TWO FRONT TOWING DEVICES
O 6PB1	REAR TOWING DEVICE	TWO REAR TOW HOOKS (FRAME MOUNTED)
S 0SAZ1X	SPARE TIRE CARRIER	WITHOUT SPARE TIRE CARRIER

CAB EXTERIOR

S 2D05	CAB SUSPENSION	MECHANICAL CAB SUSP W/SHOCKS
S 21A1	AUXILIARY REAR WINDOW	STANDARD REAR WINDOW
S D2A1	WIPER BLADE	BASIC WIPER BLADE
S 28A1	FRONT GRILLE	BLACK MOLDED FRONT GRILLE
S H6A1	BUG SCREEN	BUG SCREEN BEHIND GRILLE
O LZC2	AIR HORN	DUAL ROOF MOUNTED BRIGHT AIR HORNS, DUAL TONE
S 3F51	EXTERIOR SIDE VIEW MIRRORS	BLACK VOCATIONAL MIRRORS W/LONG ARMS
O 3GB1	EXTERIOR MIRROR FEATURES	HEATED MIRROR BOTH SIDES
S 4340	AUXILIARY DOWN VIEW MIRROR	DOWN VIEW MIRROR OVER PASSENGER DOOR
O EDB1	AUXILIARY MIRROR, HOOD	TRIPOD HOOD MOUNTED MIRROR, BOTH SIDES, STANDARD CONVEX, BRIGHT FINISH
S 4NB1	EXTERIOR SUNVISOR	FIBERGLASS EXTERIOR SUNVISOR W/LED MARKER LAMPS

CAB INTERIOR

S 540051	INTERIOR TRIM PACKAGE	PERFORMANCE NEO-CLASSIC
S 541001	INTERIOR TRIM COLOR	GRANITE INTERIOR TRIM COLOR
S 520034	DRIVER SEAT PACKAGE	NATIONAL AIR SUSPENSION HIGH BACK DRIVER SEAT
S 521038	PASSENGER SEAT PACKAGE	NATIONAL STATIONARY TOOL BOX HIGH BACK
O D7G1	SEAT UPHOLSTERY	CORDURA SEAT UPHOLSTERY
O 3PA1	SEAT ARMREST	INBOARD DRIVER SEAT ARMREST
S K7AA1X	SAFETY BELT LENGTH	STANDARD SAFETY BELT LENGTH
S 4AB1	CLIMATE UNIT	INTEGRAL AC W/HEATER-MANUAL CONTROLS
S 4125	PARKING HEATER	WITHOUT PARKING HEATER
S M5A1	DOG HOUSE	DOG HOUSE TWO PIECE



S 6WA1	CENTER CONSOLE FOR BODY CONTROLS	MOUNTING PLATE ONLY FOR BODY CONTROLS
O L3Z1	ELECTRICAL CENTER OUTLET	NO BODY BUILDER ELEC PREP KIT PROVIDED
S AMA1	FLOOR COVERING, FRONT	GRAY RUBBER FLOOR MAT
O 4JC1	STORAGE OVERHEAD DRIVER	NETTED OVERHEAD STORAGE (DRIVER/PASSENGER SIDES)
O 571003	GAUGE PACKAGE	MEDIUM INSTR LEVEL/FULL DISPLAY
S 0RAD1X	DPF REGENERATION CONTROLS	DPF REGEN CONTROL, AUTO REGEN IN MOTION, MANUAL PARKED REGEN, MANUAL INHIBIT
S PFA1	OUTDOOR/INDOOR TEMPERATURE GAUGE	DASH MOUNTED OUTDOOR TEMPERATURE GAUGE
S PVA2	AIR RESTRICTION INDICATOR	GRADUATED ARI ON FILTER
S N8D1	SPEEDOMETER GRADUATION	MPH SPEEDOMETER GRADUATION
O PAB1	CIRCUIT PROTECTION	SEMI-AUTO RESET TYPE II BREAKERS

LIGHTING

O NJZ1	AUXILIARY LAMPS	NO AUXILIARY LAMPS PROVIDED
S 836002	HEADLAMPS	HALOGEN HEADLAMPS
S LSG1	DAYTIME RUNNING LAMPS	EQUIPPED WITH DAYTIME RUNNING LIGHTS
S NEC1	STOP AND TAIL LIGHTS	DUAL WITH INTEGRAL BACKUP LIGHTS
S NPB1	TURN SIGNAL SWITCH	SELF CANCELLING TURN SIGNAL SWITCH

AUDIO SYSTEM

O F8B2	AUDIO SYSTEM	AM/FM/CD
S 19AZ1X	SATELLITE RADIO ANTENNA	NO SATELLITE RADIO ANTENNA PROVIDED
O 5CD1	RADIO SPEAKERS	SPEAKERS IN DASHBOARD & DOOR
S 5JZ1	CB RADIO MOUNTING	NO CB RADIO MOUNTING PROVIDED
O 5BN1	CB ANTENNA	MULTIPURPOSE ANTENNA (RAMI) SINGLE MIRROR MOUNTED AM/FM/CB ANTENNA W/LEAD FOR CB

MISC CAB EQUIPMENT

S 2WA1	STEERING WHEEL	18" VOLVO SAFETY SPORT STEERING WHEEL
S DUA1	SRS AIR BAG	SRS AIR BAG-DRIVERSIDE ONLY
O 2X30	WINDOW LIFT	POWER WINDOW LIFT PASSENGER DOOR
S 3AB1	DOOR LOCKS CAB	MANUAL CAB DOOR LOCKS
S 20A1	KEY TYPE	BASIC UNIQUE KEY
S 8BA1	KEY QUANTITY PER UNIT	2 KEYS PROVIDED PER UNIT



O EAC1	AUXILIARY SWITCH	THREE (3) AUXILIARY SWITCHES W/WIRING
S OIA1	HOOD CATCH CONTROL	HOOD CATCH CONTROL INTERIOR
S NIA1	ELECTRICAL DASH OUTLET	ONE 12 VOLT DASH OUTLET
S M9AZ1X	ELECTRICAL SLEEPER OUTLET	NO ELECTRICAL SLEEPER OUTLET PROVIDED
O 40L2	FIRE EXTINGUISHER	5 POUND ABC DRY TYPE, RECHARGEABLE, MOUNTED IN CAB
O 4V31	AUXILIARY SAFETY EQUIPMENT	TRIANGLE REFLECTOR KIT

WHEELS AND TIRES FRONT

S 084463	RIM/WHEEL PACKAGE FRONT	22.5X9.00 HAYES LEMMERZ STEEL PREPAINTED WHITE 286BC 5 HAND HOLES HUB PILOTED
S 093553	TIRE PACKAGE FRONT	315/80R22.5L BRIDGESTONE M860 (20000 LBS. GAWR)
S 907002	FRONT WHEEL & TIRE QUANTITY	TWO FRONT WHEELS & TIRES

WHEELS AND TIRES REAR

S 085093	RIM/WHEEL PACKAGE REAR	22.5X8.25 HAYES LEMMERZ STEEL PREPAINTED WHITE 286BC 5 HAND HOLES HUB PILOTED
O 094075	TIRE PACKAGE REAR	11R22.5G BRIDGESTONE M711 (24700 lbs. GAWR)
S 908008	DRIVE WHEEL & TIRE QUANTITY	EIGHT DRIVE WHEELS & TIRES

PAINT

S 950800	CAB PAINT SCHEME	SINGLE COLOR PAINT
S 955049	CAB PAINT TYPE	DUPONT ELITE BC ONLY-SOLID
S 9801T4	FIRST CAB COLOR	GLACIER WHITE P3029
S 9861U1	CHASSIS COLOR	BLACK P3036
S 987950	BUMPER COLOR	SAME AS FIRST CAB COLOR
S 988401	DISC WHEEL OR RIM COLOR	STEEL DISC WHEELS-PREPAINTED WHITE, POWDER-COAT, ALUMINUM OR STYLIZED DISC-UNPAINTED
S 989949	SPOKE WHEEL / HUB COLOR	SPOKE WHL/HUB SAME AS CHASSIS-AL UNPTD

BUSINESS SERVICES

S D6E1	COMMUNICATION EQUIPMENT	VOLVO LINK
S 886003	VOLVO ACTION SERVICE AGREEMENT	SILVER LEVEL VOLVO ACTION SERVICE WITH VOLVO LINK SENTRY
S 38CN	OPERATOR'S MANUAL LANGUAGE	ENGLISH

WARRANTY

S 898002	WARRANTY QUALIFICATION	STANDARD WARRANTY QUALIFIED
----------	------------------------	--------------------------------

Prepared By : PETE BARBIS Dealer Id : 5319D
Model : VHD64F200 Customer : LEE COUNTY
Deal : Lee County / Lee County/FSA



S 899007	WARRANTY TYPE	HEAVY DUTY STAND ARD BASE COVERAGE 12 MONTHS/ 100,000 MILES/ 3250_HOURS, GVW<80,000_LBS
S 948001	2007 EPA SURCHARGE	2007 EPA SURCHARGE NET/NET NO DISCOUNT
O 694089	TRANSMISSION PROGRAM CODE	VHD TRUCK_W/ 4500_RDS TRA NSMISSION_MAINTENANCE_PRICE



Dimension

	DIMENSION	LENGTH
FE	Front Frame Extension(in)	0.0
BA	Bumper to Front Axle(in)	29.1
WB	Wheelbase(in)	222.0
OH	Overhang(in)	55.0
OL	Overall Length(in)	306.1
BBC	Bumper to Back of Cab(in)	113.6
EBBC	Eff. Bumper to Back of Cab(in)	113.6
ECA	Eff. Cab to Rear Axle(in)	137.5
EAC	Eff. Front Axle to Back of Cab(in)	84.5
ECEF	Eff. Cab to End of Frame(in)	192.5
5W	Unladen 5th Wheel Height(in)	0.0
FH	Unladen Frame Height(in)	44.1
CH	Cab Height(in)	74.3
OVH	Overall Height(in)	118.4
DCG	Driver CG(in)	64.5

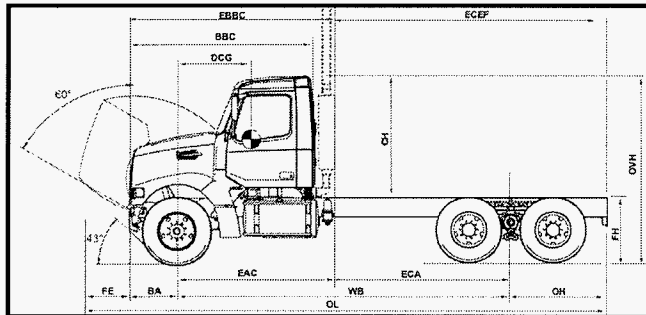



FLORIDA SHERIFFS ASSOCIATION, FLORIDA ASSOCIATION OF COUNTIES & FLORIDA FIRE CHIEFS' ASSOCIATION

52,000 LB. GVWR CAB & CHASSIS - 4X6 TANDEM AXLE TRUCK SPECIFICATION #49

2007/2008 Autocar WX64
2007/2008 Freightliner M2-112
2007/2008 International 7600
2007/2008 Kenworth T800
2007/2008 Mack C or G Series
2007/2008 Peterbilt 367
2007/2008 Sterling L Series
2007/2008 Volvo V Series
2007/2008 Western Star 4900

ALL ITEMS FACTORY INSTALLED UNLESS OTHERWISE INDICATED

INSTRUCTIONS: Listed above, you will find the model numbers of the vehicles that will be included in this year's contract.

1. ENGINE:

- a. 350 HP 6 cylinder diesel engine, 11L minimum

2. TRANSMISSION & CLUTCH:

- a. The following or approved equivalents are acceptable:
- b. Fuller 14210B 10 Speed Manual with OD

3. ENGINE EQUIPMENT:

- a. Alternator – 12 volt 100A
- b. Premium engine hoses
- c. Injection pump – electronic engine control
- d. Radiator – aluminum core
- e. Air restriction monitor – intake mounted

4. CAB:

- a. Cab – welded steel galvanized or aluminum shell with rust preventative coating.
- b. Floor covering – black rubber mats
- c. Seating – driver air suspension mid back, passenger fixed mid back.
- d. Steering wheel – 18" two spoke
- e. Standard air conditioning

5. FRAME:

- a. Frame – steel construction matched to GVW and mounted body of truck.
- b. Wheelbase – 187"
- c. Front bumper – painted steel
- d. Fuel tank – 70 gallon, minimum
- e. Air dryer – bendix AD9 heated, or approved equivalent.

6. SAFETY:

- a. Horn – single air trumpet
- b. Mirrors – West Coast to include 7.5" convex mounted to lower mirror bracket.
- c. Windshield wipers – 2 speed with intermittent feature
- d. Brakes – Meritor "S" cam type 15" x 4" Q + front and Meritor 16.5" x 7" Q + rear with antilock without automatic traction control, or approved equivalent.
- e. Slack adjusters – Haldex automatic front and rear.
- f. Daytime running lights.
- g. Backup alarm – pollak 41-722 constant audible, or approved equivalent (mounted on rear cross member).

7. FRONT AXLE:

- a. Front axle – 12,000 lb.
- b. Front wheels – steel 10 hole hub piloted
- c. Front tires – 11R22.5 Goodyear G397LHS, steer or approved equivalent.
- d. Front hubs – Ferrous, or approved equivalent.

8. REAR AXLE:

- a. Rear axle – 40,000 lb.
- b. Rear wheels – steel 10 hole hub piloted
- c. Rear tires – 11R22.5 Goodyear G124 unisteel traction or approved equivalent.
- d. Hubs – Ferrous, or approved equivalent.
- e. Power divider with warning light and buzzer (includes in cab control)

9. ELECTRICAL:

- a. Circuit protection – fuses except headlamp and wiper circuits which utilize circuit breakers.
- b. Hand throttle – electronic hand throttle operated through cruise control when in PTO mode only.
- c. Engine protection – engine shut down system monitoring high water temp, low oil pressure, high exhaust temp, high transmission temp.

10. CONDITIONS

In addition to equipment specified, vehicle shall be equipped with all standard equipment as specified by the manufacturer for this model and shall comply with all EPA Emission Standards and all Motor Vehicle Safety Standards as established by the U.S. Department of Transportation regarding the manufacture of motor vehicles.

The successful bidder shall be responsible for delivering vehicles that are properly serviced, clean and in first class operating condition. Pre-delivery service, at a minimum, shall include the following:

- a. Complete lubrication.
- b. Check all fluid levels to assure proper fill.
- c. Adjustment of engine to proper operating condition.
- d. Inflate tires to proper pressure.
- e. Check to assure proper operation of all accessories, gauges, lights, and mechanical features.
- f. Focusing of headlights.
- g. Cleaning of vehicles, if necessary, and removal of all unnecessary tags, stickers, papers, etc. **DO NOT** remove window price sticker or supplied line sheet.

Dump
Truck



**FLORIDA SHERIFFS ASSOCIATION,
FLORIDA ASSOCIATION OF COUNTIES &
FLORIDA FIRE CHIEFS' ASSOCIATION**

**52,000 LB. GVWR CAB & CHASSIS - 4X6 TANDEM AXLE TRUCK
SPECIFICATION #49**

2007/2008 Volvo V Series

The Volvo V Series purchased through this contract comes with all the standard equipment as specified by the manufacturer for this model and FSA's base vehicle specification(s) requirements which are included and made a part of this contract's vehicle base price as awarded by specification by zone.

ZONE:	Western	Northern	Central	Southern
BASE PRICE:	\$87,299.00	\$87,049.00	\$87,177.00	\$82,828.00

While the Florida Sheriffs Association, Florida Association of Counties and Florida Fire Chiefs' Association have attempted to identify and include those equipment items most often requested by participating agencies for full size vehicles, we realize equipment needs and preferences are going to vary from agency to agency. In an effort to incorporate flexibility into our program, we have created specific add/delete options which allow the purchaser to tailor the vehicle to their particular wants or needs.

The following equipment delete and add options and their related cost are provided here to assist you in approximating the total cost of the type vehicle(s) you wish to order through this program. Simply deduct the cost of any of the following equipment items you wish deleted from the base unit cost and/or add the cost of any equipment items you wish added to the base unit cost to determine the approximate cost of the type vehicle(s) you wish to order.

NOTE: An official listing of all add/delete options and their prices should be obtained from the appropriate dealer in your zone when preparing your order. Additional add/delete options other than those listed here may be available through the dealers, however, those listed here must be honored by the dealers in your zone at the stated prices.

VEHICLE:	V Series	V Series	V Series	V Series
DEALER:	Nextran Truck Center - Lake City	Nextran Truck Center - Lake City	Nextran Truck Center - Tampa	General GMC Truck Sales & Service, Inc.
ZONE:	Western	Northern	Central	Southern
BASE PRICE:	\$87,299.00	\$87,049.00	\$87,177.00	\$82,828.00

Order Code	Delete Options	Western & Northern	Central	Southern
	Engine/transmission (specify)	NA		NA
	Engine/transmission (specify)	NA		NA
	Engine/transmission (specify)	NA		NA
	Engine/transmission (specify)	NA		NA

Order Code	Add Options	Western & Northern	Central	Southern
1017A7 ¹	Engine (specify)	(\$2,212.00) ¹		(\$1,850.00) ³
1017A7 ²	335 HP ¹			
1017A7 ³	VOLVO 335 HP ² Volvo 13 liter @ 335hp ³			
1017A8 ¹	Engine (specify)	\$412.00 ¹	\$412.00 ²	\$595.00 ³
1017A8 ²	405 ¹			
1017B0 ³	VOLVO 405 HP ² Volvo 13 liter @ 405hp ³			
1017B1 ³	Engine (specify)	NA		\$1,185.00 ³
	Volvo 13 liter @ 425hp ³			
RWJJ ¹	Transmission (specify)	\$399.00 ¹	\$399.00 ²	\$998.00 ³
RWJJ ²	FULLER 16210C ¹			
RWLP ³	EATON FULLER RTO16210C ² RTO 16908LL ³			
RWKB ³	Transmission (specify)	NA		\$695.00 ³
	RTO 14908LL ³			
RWWC ³	Transmission (specify)	NA		\$3,883.00 ³
	RTO 16910B-AS3 Autoshift 10 speed ³			
VHD585 ¹	58,000 lb. GVWR package	\$919.00 ¹	\$919.00 ²	\$1,213.00 ³
VHD585 ²				
VHD585³				
VHD64 ¹	64,000 lb. GVWR package	\$3,107.00 ¹	\$3,107.00 ²	\$3,356.00 ³
VHD64 ²				
330444 ³				
RWBO ¹	Allison 4500RDS Auto Transmission to include synthetic oil, TES 295 or approved equivalent	\$13,906.00 ¹	\$13,906.00 ²	\$15,835.00 ³
RWBO ²				
RWB0 ³				
Z9B1 ¹	Double Frame: full steel insert	\$703.00 ¹	\$703.00 ²	\$949.00 ³
Z9B1 ²				
Z9B1 ³				
370333 ¹	Front Axle: 14,600 lb rating to include equal capacity steering gear and springs	Std ¹	Std ²	Incl.
370333 ²				

VEHICLE:	V Series	V Series	V Series	V Series
DEALER:	Nextran Truck Center - Lake City	Nextran Truck Center - Lake City	Nextran Truck Center - Tampa	General GMC Truck Sales & Service, Inc.
ZONE:	Western	Northern	Central	Southern
BASE PRICE:	\$87,299.00	\$87,049.00	\$87,177.00	\$82,828.00

370336 ¹ 370336 ² 370-20 ³	Front Axle: 20,000 lb. rating to include equal capacity steering gear and springs	\$1,581.00 ¹	\$1,531.00 ²	\$1,217.00 ³
330444 ¹ 330444 ² 330-46 ³	Rear Axle: 46,000 lb Arvin Meritor, Eaton, Mack, or equivalent	\$1,526.00 ¹	\$1,526.00 ²	\$2,143.00 ³
	Rigid Lift Axle: Pusher / Tag 13,200 lb rating air lift to include 11R-22.5 tires with steel wheels	NA	NA	NA
NEX13S ¹ NEX13S ² 335021 ³	Steerable Lift Axle: Pusher / Tag 13,200 lb rating air lift to include 11R-22.5 tires with steel wheels	\$6,000.00 ¹	\$6,000.00 ²	\$5,020.00 ³
NEX20R ¹ NEX20R ² 335023 ³	Rigid Lift Axle: Pusher / Tag 20,000 lb rating air lift to include 11R-22.5 tires with steel wheels	\$5,000.00 ¹	\$5,200.00 ²	\$5,852.00 ³
NEX20S ¹ NEX20S ²	Steerable Lift Axle: Pusher / Tag 20,000 lb rating air lift to include 11R-22.5 tires with steel wheels	\$7,500.00 ¹	\$7,500.00 ²	NA
350-40A ³	Rear Suspension: 40,000 lb air ride	NA	NA	\$685.00 ³
350380 ¹ 350380 ² 350-46T ³	Rear Suspension: 46,000 lb Chalmers, Hendrickson, Mack, Volvo "T" ride or equivalent	\$1,526.00 ¹	\$1,526.00 ²	\$107.00 ³
350312 ¹ 350312 ² 350-46A ³	Rear Suspension: 46,000 lb air ride	\$1,921.00 ¹	\$1,921.00 ²	\$750.00 ³
OXCTS11177 ¹ JHE ² ED-12 ³	12 yd. dump body with hoist and electric tarp system. State model bid. JHE114-40-12 W/HOTSHIFT PTO+GRD LEVEL TARP ²	\$9,420.00 ¹	\$11,315.00 ²	\$11,898.00 ³
OXCTS11178 ¹ JHE ² ED-18 ³	18 yd. dump body with hoist and electric tarp system. State model bid. JHE216-52-18 W/HOTSHIFT PTO+ELECTRIC TARP ²	\$11,515.00 ¹	\$12,720.00 ²	\$12,680.00 ³
NWFW ¹ NWFW ² HYD-3WF ³	Hydraulic Wet Line Kit for transfer trailer/or walking floor	\$5,260.00 ¹	\$5,260.00 ²	\$3,157.00 ³
GP60 ¹ JHE-GAL ² RO-22 ³	Rolloff hoist system and tarp system. State model bid. GALBREATH U5-OR-174+PIONEER TARP 4500SARG ²	\$28,600.00 ¹	\$27,600.00 ²	\$39,469.00 ³
424073 ¹ 424073 ² 424073 ³	Dual fuel tanks, or equivalent <i>LOCAL? How many gallon tanks?</i>	\$268.00 ¹	\$268.00 ²	\$124.00³
2D30 ¹ 2D30 ² 2D30 ³	Cab suspension - air ride	\$45.00 ¹	\$45.00 ²	\$159.00 ³



VEHICLE:	V Series	V Series	V Series	V Series
DEALER:	Nextran Truck Center - Lake City	Nextran Truck Center - Lake City	Nextran Truck Center - Tampa	General GMC Truck Sales & Service, Inc.
ZONE:	Western	Northern	Central	Southern
BASE PRICE:	\$87,299.00	\$87,049.00	\$87,177.00	\$82,828.00

ALL ¹

Optional mounted body (specify) <i>TOO MANY OPTIONS TO LIST, OPTIONS ADDED AT COST ¹</i>	Std ¹	NA
Optional mounted body (specify)	NA	NA
Optional mounted body (specify)	NA	NA
Optional mounted body (specify)	NA	NA
Optional mounted equipment/body (specify)	NA	NA
Optional mounted equipment/body (specify)	NA	NA
Optional mounted equipment/body (specify)	NA	NA
Optional mounted equipment/body (specify)	NA	NA
Optional equipment (specify)	NA	NA
Optional equipment (specify)	NA	NA
Optional equipment (specify)	NA	NA
Optional equipment (specify)	NA	NA

Complete set of manuals
 AM/FM/CD Radio
 Air release tail gate latch
 Pintel Hitch with glad hands
 All terrain tires
 7 round trailer connector

**BID AWARD
ANNOUNCEMENT**

06-14-0821A

**PURSUIT,
ADMINISTRATIVE NON-PURSUIT,
UTILITY VEHICLES, TRUCKS & VANS,
& OTHER FLEET EQUIPMENT**

*Participating Sheriff's Offices & Local Governmental
Agencies of the State of Florida*

Coordinated By

The

**Florida Sheriffs Association,
Florida Association of Counties &
Florida Fire Chiefs' Association**



TABLE OF CONTENTS

ORDERING INSTRUCTIONS	6
Overview of Awarded Specifications	7
Awarded Dealers	13
Basic Information REQUIRED for Purchase Orders	16
District Map	17

SPECIFICATIONS 1-45 AND 51-60 WERE AWARDED ON BID 06-14-0821

- Specification #1 – Full Size Vehicles - RWD (Police Package)
- Specification #2 – Full Size Vehicles - FWD (Police Package)
- Specification #3 – Full Size Utility Vehicles - RWD (Police Package)
- Specification #4 – Full Size 4-Door Administrative Vehicles
- Specification #5 – Mid Size 4-Door Administrative Vehicles
- Specification #6 – Compact 4-Door Administrative Vehicles
- Specification #7 – Hybrid 4-Door Administrative Vehicles
- Specification #8 – Small 4 Passenger Electric Vehicle
- Specification #9 – Off-Road Utility Vehicle
- Specification #10 – Police Motorcycle
- Specification #11 – Motorcycle
- Specification #12 – Hybrid Small Size 4-Door Utility Vehicles - FWD
- Specification #13 – Hybrid Small Size 4-Door Utility Vehicles - 4x4
- Specification #14 – Small Size 4-Door Utility Vehicles - 4x2
- Specification #15 – Small Size 4-Door Utility Vehicles - 4x4 or AWD
- Specification #16 – Mid Size 4-Door Utility Vehicles - 4x2
- Specification #17 – Mid Size 4-Door Utility Vehicles - 4x4
- Specification #18 – Full Size 4-Door Utility Vehicles - 4x2
- Specification #19 – Full Size 4-Door Utility Vehicles - 4x4
- Specification #20 – 1/2 Ton 4-Door Extended Wheelbase Utility Vehicles - 4x2
- Specification #21 – 1/2 Ton 4-Door Extended Wheelbase Utility Vehicles - 4x4
- Specification #22 – 3/4 Ton 4-Door Extended Wheelbase Utility Vehicles - 4x2
- Specification #23 – 3/4 Ton 4-Door Extended Wheelbase Utility Vehicles - 4x4
- Specification #24 – 7 Passenger Mini Van - FWD
- Specification #25 – 8 Passenger Van - RWD
- Specification #26 – 12 Passenger Van
- Specification #27 – 15 Passenger Van
- Specification #28 – Utility Cargo Van
- Specification #29 – Compact Pickup Truck - 4x2
- Specification #30 – Compact Pickup Truck - 4x4
- Specification #31 & #32 – Hybrid 1/2 Ton Extended Cab Pickup Truck
- Specification #33 – 1/2 Ton Pickup Truck - 4x2
- Specification #34 – 1/2 Ton Pickup Truck - 4x4
- Specification #35 – 3/4 Ton Pickup Truck - 4x2
- Specification #36 – 3/4 Ton Pickup Truck - 4x4

- Specification #37 – 1 Ton Pickup Truck (Dual Rear Wheel) - 4x2
- Specification #38 – 1 Ton Pickup Truck (Dual Rear Wheel) - 4x4
- Specification #39 – 1 Ton Cab & Chassis (Dual Rear Wheel) - 4x2
- Specification #40 – 1 Ton Cab & Chassis (Dual Rear Wheel) - 4x4
- Specification #41 – 12,000 lb. GVWR Minimum Tilt Cab & Chassis
- Specification #42 – 15,000 lb. GVWR Cab & Chassis (Dual Rear Wheel) - 4x2
- Specification #43 – 15,000 lb. GVWR Cab & Chassis (Dual Rear Wheel) - 4x4
- Specification #44 – 17,501 lb. GVWR Cab & Chassis (Dual Rear Wheel) - 4x2
- Specification #45 – 17,501 lb. GVWR Cab & Chassis (Dual Rear Wheel) - 4x4

Specification #46 – 25,500 lb. GVWR Cab & Chassis (Dual Rear Wheel) - 4x2	
Awarded Dealer(s).....	18
Base Specifications.....	20
Ford F-650.....	22
Chevrolet Kodiak 7500.....	29
GMC TC7500.....	35
Freightliner M2.....	40
Hino 268A.....	45
International 4300V SBA.....	51
Kenworth T300.....	57
Peterbilt 330.....	63
Sterling Acterra.....	69

Specification #47 – 30,000 lb. GVWR Cab & Chassis (Dual Rear Wheel) - 4x2	
Awarded Dealer(s).....	74
Base Specifications.....	76
Ford F-750.....	78
Chevrolet CC7500.....	85
GMC TC7500.....	92
Freightliner M2.....	98
Hino 338.....	105
International 4300V SBA.....	111
Kenworth T300.....	117
Peterbilt 335.....	123
Sterling Acterra.....	129

Specification #48 – 52,000 lb. GVWR Cab & Chassis 4x6 Tandem Axle Truck Tractor	
Awarded Dealer(s).....	135
Base Specifications.....	137
Autocar WX64.....	139
Freightliner M2-112.....	142
International 7600.....	145
Kenworth T800.....	148
Mack C or G Series.....	151
Peterbilt 367.....	154
Sterling LT9500.....	157
Volvo V Series.....	160
Western Star 4900.....	163

Specification #49 – 52,000 lb. GVWR Cab & Chassis 4x6 Tandem Axle Truck	
Awarded Dealer(s).....	166
Base Specifications.....	168
Autocar WX64.....	170

- Specification #37 – 1 Ton Pickup Truck (Dual Rear Wheel) - 4x2
- Specification #38 – 1 Ton Pickup Truck (Dual Rear Wheel) - 4x4
- Specification #39 – 1 Ton Cab & Chassis (Dual Rear Wheel) - 4x2
- Specification #40 – 1 Ton Cab & Chassis (Dual Rear Wheel) - 4x4
- Specification #41 – 12,000 lb. GVWR Minimum Tilt Cab & Chassis
- Specification #42 – 15,000 lb. GVWR Cab & Chassis (Dual Rear Wheel) - 4x2
- Specification #43 – 15,000 lb. GVWR Cab & Chassis (Dual Rear Wheel) - 4x4
- Specification #44 – 17,501 lb. GVWR Cab & Chassis (Dual Rear Wheel) - 4x2
- Specification #45 – 17,501 lb. GVWR Cab & Chassis (Dual Rear Wheel) - 4x4

Specification #46 – 25,500 lb. GVWR Cab & Chassis (Dual Rear Wheel) - 4x2	
Awarded Dealer(s).....	18
Base Specifications.....	20
Ford F-650	22
Chevrolet Kodiak 7500	29
GMC TC7500	35
Freightliner M2	40
Hino 268A.....	45
International 4300V SBA.....	51
Kenworth T300	57
Peterbilt 330	63
Sterling Acterra	69
Specification #47 – 30,000 lb. GVWR Cab & Chassis (Dual Rear Wheel) - 4x2	
Awarded Dealer(s).....	74
Base Specifications.....	76
Ford F-750	78
Chevrolet CC7500	85
GMC TC7500	92
Freightliner M2	98
Hino 338	105
International 4300V SBA.....	111
Kenworth T300	117
Peterbilt 335	123
Sterling Acterra	129
Specification #48 – 52,000 lb. GVWR Cab & Chassis 4x6 Tandem Axle Truck Tractor	
Awarded Dealer(s).....	135
Base Specifications.....	137
Autocar WX64	139
Freightliner M2-112.....	142
International 7600	145
Kenworth T800	148
Mack C or G Series	151
Peterbilt 367	154
Sterling LT9500	157
Volvo V Series	160
Western Star 4900	163
Specification #49 – 52,000 lb. GVWR Cab & Chassis 4x6 Tandem Axle Truck	
Awarded Dealer(s).....	166
Base Specifications.....	168
Autocar WX64	170

Specification #49 – 52,000 lb. GVWR Cab & Chassis 4x6 Tandem Axle Truck <i>(continued)</i>	
Freightliner M2-112	173
International 7600	176
Kenworth T800	179
Mack C or G Series	183
Peterbilt 367	187
Sterling L Series	190
Volvo V Series	193
Western Star 4900	197

Specification #50 – 60,000 lb. GVWR Cab & Chassis 4x6 Tandem Axle Refuse Truck	
Awarded Dealer(s)	200
Base Specifications	201
American LaFrance Condor	203
Autocar WX64	206
Crane Carrier LET2	210
Mack MR Series	213
Peterbilt 320	217

Specification #51 – 4x4 Loader Backhoe with Canopy (Standard Stick)	
Specification #52 – 3.0 Cu. Yd. Wheel Loader (Z-Bar Linkage Bucket - Parallel Arm Option)	
Specification #53 – Motorgrader	
Specification #54 – Agriculture Type Tractor (2 Wheel Drive)	
Specification #55 – Agriculture Type Tractor with Optional Boom Mower (2 Wheel Drive)	
Specification #56 – 70 HP Track Type Canopy Tractor (Standard Track - Wide Track Optional)	
Specification #57 – 90 HP Track Type Canopy Tractor (Standard Track - Wide Track Optional)	
Specification #58 – Skid Steer Loader - 1850 lb. Operating Capacity	
Specification #59 – 15 ft. Flex Wind Rotary Mower - PTO Driven	
Specification #60 – Regenerative Air Street Sweeper	

Manufacturer's Extended Vehicle Warranty	220
Mears Motor Leasing	222



4300 SBA 4x2

Sales Proposal For:
Lee County B.O.C.C.

Presented By:
SUN STATE INTL TRKS, LLC

*Patch
Truck*

Prepared For:
Lee County B.O.C.C.
Robert D. Franceschini
2440 Thompson St.
Fort Myers, FL 33901-
(941)339 - 6265
Reference ID: N/A

Presented By:
SUN STATE INTL TRKS, LLC
Alan Beyer
6020 ADAMO DRIVE
TAMPA FL 33619
(813)621-1331

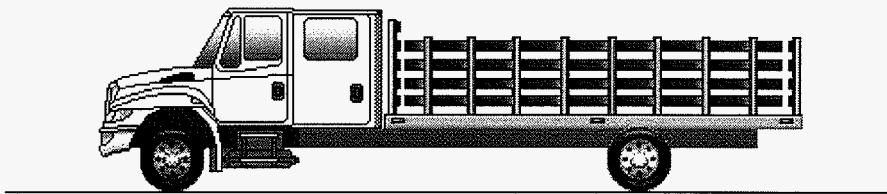

Model Profile
2008 4300 SBA 4X2 (MA025)

APPLICATION:	Stake Flat
MISSION:	Requested GVWR: 33000. Calc. GVWR: 35000 Calc. Start / Grade Ability: 26.20% / 1.89% @ 55 MPH Calc. Geared Speed: 78.2 MPH
DIMENSION:	Wheelbase: 248.0, CA: 137.0, Axle to Frame: 63.0
ENGINE, DIESEL:	{International MaxxForce DT} 50 State, 245 HP, 620 lb-ft Torque @ 1400 RPM, 2600 RPM Governed Speed, # 2 Bell Housing
TRANSMISSION, AUTOMATIC:	{ALLISON 3000_RDS_P} 4th Generation Controls; Close Ratio, 5-Speed, With Overdrive; On/Off Hwy; Includes Oil Level Sensor, With PTO Provision, Less Retarder, With 80,000-lb GVW & GCW Max.
CLUTCH:	Omit Item (Clutch & Control)
AXLE, FRONT NON-DRIVING:	{International I-120SG} I-Beam Type, 12,000-lb Capacity
AXLE, REAR, SINGLE:	{Dana Spicer 23060SH} Single Reduction, 23,000-lb Capacity, With 200 Wheel Ends Gear Ratio: 5.29
CAB:	Conventional 6-Man Crew Cab
TIRE, FRONT:	(2) 11R22.5 AH12 (HANKOOK) 503 rev/mile, load range H, 16 ply
TIRE, REAR:	(4) 11R22.5 AH12 (HANKOOK) 503 rev/mile, load range H, 16 ply
SUSPENSION, RR, SPRING, SINGLE:	Vari-Rate; 23,500-lb Capacity, With 4500 lb Auxiliary Rubber Spring
PAINT:	Cab Schematic 100GA Location 1: 9219, Winter White Chassis Schematic N/A

<u>Description</u>	<u>F/R Wt</u>	<u>Tot Wt</u>
	(lb)	(lb)
Base Chassis, Model 4300 SBA 4X2 with 248.0 Wheelbase, 137.0 CA, and 63.0 Axle to Frame.	5985/2781	8766
TOW HOOK, FRONT (2) Inside Rail, Frame Mounted.	8/0	8
FRAME RAILS Heat Treated Alloy Steel (120,000 PSI Yield); 10.250" x 3.610" x 0.375" (260.4mm x 91.7mm x 9.5mm); 456.0" (11582mm) Maximum OAL	270/424	694
BUMPER, FRONT Full Width, Aerodynamic, Steel; 0.142" Material Thickness	0/0	0
WHEELBASE RANGE 199" (505cm) Through and Including 254" (645cm)	0/0	0
AXLE, FRONT NON-DRIVING {International I-120SG} I-Beam Type, 12,000-lb Capacity	99/0	99
SUSPENSION, FRONT, SPRING Parabolic, Taper Leaf; 12,000-lb Capacity; With Shock Absorbers	72/0	72
BRAKE SYSTEM, AIR Dual System for Straight Truck Applications	56/42	98
DRAIN VALVE, AUTOMATIC {Bendix DV-2} With Heater; for Air Tank	1/0	1
AIR BRAKE ABS {Bendix AntiLock Brake System} Full Vehicle Wheel Control System (4-Channel)	9/21	30
AIR DRYER {Bendix AD-9} With Heater	24/3	27
BRAKES, FRONT, AIR CAM S-Cam; 15.0" x 4.0"; Includes 20 Sq. In. MGM Long Stroke Brake Chambers	71/0	71
BRAKES, REAR, AIR CAM 16.5" x 7.0"; Includes MGM TR3030 Long Stroke Brake Chamber and Heavy Duty Spring Actuated Parking Brake	0/251	251
AIR COMPRESSOR {Bendix Tu-Flo 550} 13.2 CFM Capacity	46/0	46
DUST SHIELDS, FRONT BRAKE	3/0	3
DUST SHIELDS, REAR BRAKE	0/6	6
STEERING COLUMN Stationary	0/0	0
STEERING WHEEL 2-Spoke, 18" Diam., Black	0/0	0
STEERING GEAR {Sheppard M-100} Power	25/0	25
EXHAUST SYSTEM Single, Horizontal, Aftertreatment Device, Frame Mounted Right Side Back of Cab, Includes Horizontal Tailpipe	0/0	0
ELECTRICAL SYSTEM 12-Volt, Standard Equipment	0/0	0
CIGAR LIGHTER	1/0	1
ALTERNATOR {Leece-Neville 8LHP2172VAH} Brush Type; 12 Volt 110 Amp. Capacity, Pad Mounted	0/0	0
BODY BUILDER WIRING Back of Standard Cab at Left Frame or Under Extended or Crew Cab at Left Frame; Includes Sealed Connectors for Tail/Amber Turn/Marker/ Backup/Accessory Power/ Ground and Sealed Connector for Stop/Turn	2/0	2
BATTERY SYSTEM {International} Maintenance-Free (2) 12-Volt 1300CCA Total.	0/0	0
RADIO {Panasonic CQR-111} AM/FM, With Cassette Player, Includes Multiple Dual Cone Speakers	6/0	6
BACK-UP ALARM Electric, 102 dBA	0/3	3

<u>Description</u>	<u>F/R Wt</u>	<u>Tot Wt</u>
	(lb)	(lb)
WINDSHIELD WIPER SPD CONTROL Force Wipers to Slowest Intermittent Speed When Park Brake Set and Wipers Left on for a Predetermined Time	0/0	0
HEADLIGHTS Halogen; Composite Aero Design for Two Light System; Includes Daytime Running Lights	0/0	0
ENGINE SHUTDOWN Automatic; With 30 Second Delay, With International Engines	1/0	1
TEST EXTERIOR LIGHTS Pre-Trip Inspection will Cycle all Exterior Lamps Except Back-up Lights	0/0	0
HEADLIGHTS ON WWIPERS Headlights Will Automatically Turn on if Windshield Wipers are turned on	0/0	0
INDICATOR, LOW COOLANT LEVEL With Audible Alarm	1/0	1
STARTING MOTOR {Leece-Neville M130D} 12 Volt; Less Thermal Over-Crank Protection	0/0	0
CIRCUIT BREAKERS Manual-Reset (Main Panel) SAE Type III With Trip Indicators, Replaces All Fuses Except For 5-Amp Fuses	0/0	0
GRILLE Chrome	0/0	0
INSULATION, UNDER HOOD for Sound Abatement	1/0	1
INSULATION, SPLASH PANELS for Sound Abatement	1/0	1
FRONT END Tilting, Fiberglass, With Three Piece Construction	0/0	0
PAINT SCHEMATIC, PT-1 Single Color, Design 100	0/0	0
PAINT TYPE Base Coat/Clear Coat, 1-2 Tone	0/0	0
CLUTCH Omit Item (Clutch & Control)	-67/-8	-75
ENGINE, DIESEL {International MaxxFORCE DT} 50 State, 245 HP, 620 lb-ft Torque @ 1400 RPM, 2600 RPM Governed Speed, # 2 Bell Housing	0/0	0
FAN DRIVE {Borg-Warner SA85} Viscous Screw On Type	3/0	3
FEDERAL EMISSIONS for 2004; for International VT365, DT466 and DT570 Engines	0/0	0
RADIATOR Aluminum; 2-Row, Cross Flow, Over Under System, 717 SqIn Louvered, With 313 SqIn Charge Air Cooler. With In-Tank Transmission Cooler, 4.25" Core	0/0	0
AIR CLEANER Single Element	0/0	0
THROTTLE, HAND CONTROL Engine Speed Control; Electronic, Stationary, Variable Speed; Mounted on Steering Wheel	0/0	0
FEDERAL EMISSIONS 2007 for International MaxxFORCE DT Engines (DT466)	0/0	0
ENGINE CONTROL, REMOTE MOUNTED Provision for; Includes Wiring for Body Builder Installation of PTO Controls; With Ignition Switch Control for International post 2007 Emissions Electronic Engines	0/0	0
EXPANDED ENGINE TEMP EFFECTS to Allow Higher Engine Operating Temperature Range; Includes Nylon Surge Tank and 15 psi Pressure Cap	0/0	0
TRANSMISSION, AUTOMATIC {ALLISON 3000_RDS_P} 4th Generation Controls; Close Ratio, 5-Speed, With Overdrive; On/Off Hwy; Includes Oil Level Sensor, With PTO Provision, Less Retarder, With 80,000-lb GVW & GCW Max.	183/51	234

<u>Description</u>	<u>F/R Wt</u>	<u>Tot Wt</u>
	(lb)	(lb)
TRANSMISSION SHIFT CONTROL {ALLISON} Push-Button Type; for Allison 3000 & 4000 Series Transmission	0/0	0
TRANSMISSION OIL {Castrol TranSynd} Synthetic; 29 thru 42 Pints	0/0	0
ALLISON SPARE INPUT/OUTPUT for Rugged Duty Series (RDS); General Purpose Trucks, Construction	0/0	0
AXLE, REAR, SINGLE {Dana Spicer 23060SH} Single Reduction, 23,000-lb Capacity, With 200 Wheel Ends	0/0	0
SUSPENSION, RR, SPRING, SINGLE Vari-Rate; 23,500-lb Capacity, With 4500 lb Auxiliary Rubber Spring	0/66	66
FUEL TANK Top Draw; D Style, Steel, 50 U.S. Gal., 189 L Capacity, 16" Deep, With Quick Connect Outlet, Mounted Right Side, Under Cab	0/0	0
CAB Conventional 6-Man Crew Cab	104/250	354
SEAT, PASSENGER Omit Item	0/0	0
GAUGE CLUSTER English With English Electronic Speedometer	0/0	0
GAUGE, OIL TEMP, ALLISON TRAN	1/0	1
IP CLUSTER DISPLAY On Board Diagnostics Display of Fault Codes in Gauge Cluster	0/0	0
SEAT, FRONT BENCH {Gra-Mag} Full Width; Vinyl, With Fixed Mid Back	0/0	0
SEAT, REAR {International} BENCH; Full Width; Vinyl, With Fixed Back and Two Integral Outboard Headrest	69/22	91
MIRRORS (2) {Lang Mekra} Rectangular, 7.44" x 14.84", Brackets Breakaway Type, With 102" Wide Spacing, With 7.44" sq. Convex Both Sides	2/0	2
INSTRUMENT PANEL Center Section, Flat Panel	0/0	0
AIR CONDITIONER {International Blend-Air} With Integral Heater & Defroster	0/0	0
CAB INTERIOR TRIM Deluxe; for Crew Cab	0/0	0
CAB REAR SUSPENSION Air Bag Type	27/8	35
WHEELS, FRONT DISC; 22.5" Painted Steel, 2 Hand Hole, 10 Stud (285.75MM BC) Hub Piloted, Flanged Nut, Metric Mount, 8.25 DC Rims; With Steel Hubs.	91/0	91
WHEELS, REAR DUAL DISC; 22.5" Painted Steel, 2 Hand Hole, 10-Stud (285.75MM BC) Hub Piloted, Flanged Nut, Metric Mount, 8.25 DC Rims; With Steel Hubs	0/67	67
WHEEL SEALS, FRONT {International} Oil-Lubricated Wheel Bearings	0/0	0
(2) TIRE,FRONT 11R22.5 AH12 (HANKOOK) 503 rev/mile, load range H, 16 ply	88/0	88
(4) TIRE,REAR 11R22.5 AH12 (HANKOOK) 503 rev/mile, load range H, 16 ply	0/176	176
Total Component Weight:	7183/4163	11346
HD INDUSTRIES TCM-425-135 POTHOLE PATCHER	0/0	0
Total Body Allied:	0/0	0
STEEL SURCHARGE	0/0	0

Description

SERVICE MANUALS - CD VERSION

<u>F/R Wt</u>	<u>Tot Wt</u>
(lb)	(lb)
0/0	0
0/0	0

Total Goods Purchased:

The weight calculations included in this proposal are an estimate of future vehicle weight. The actual weight as manufactured may be different from the estimated weight. International Truck and Engine Corp. shall not be liable for any consequences resulting from any differences between the estimated weight of a vehicle and the actual weight.

<u>Description</u>	<u>Price</u>
Factory List Prices:	
Product Items	
Service Items	
Total Factory List Price Including	\$87,550.00
Options:	
Total Goods Purchased:	\$1,500.00
FIRE EXT. & TRIANGLE KIT	
Total Preparation And Delivery:	\$100.00
Freight Charge	
Total Freight:	\$1,705.00
Total Factory List Price Including	\$90,855.00
Freight:	
Less Customer Allowance:	(\$26,103.00)
Total Vehicle Price:	\$64,752.00
Total Body/Allied Equipment:	\$55,628.00
Total Sale Price:	\$120,380.00
Total Per Vehicle Sales Price:	\$120,380.00
Net Sales Price:	\$120,380.00

Please feel free to contact me regarding these specifications should your interests or needs change. I am confident you will be pleased with the quality and service of an International vehicle.

SALE PRICE DOES NOT INCLUDE: TAX, TITLE OR TAG FEES.

FLORIDA SHERIFF'S ASSOCIATION BID# 06-14-0821A
SPEC # 47

BASE BID (SOUTHERN REGION)	\$ 41,600.00
OPTIONS:	
1. 16196 (CREW CAB)	8,254.00
2. 13WLE (SYNTHETIC TRANS. LUBE)	160.00
3. 4EBD (AIR DRYER)	537.00
4. 4722 (MOISTURE EJECTORS)	140.00
5. 8WCL (AIR HORN)	50.00
6. 4080-03 (33K GVW PKG -245 HP 3000RDS)	10,400.00
7. 156CAG (156" CAB TO AXLE)	2,891.00
8. SAFETY (FIRE EXT. & TRIANGLE KIT)	100.00
9. ALARM (BACKUP ALARM)	120.00
10. DSM (SERVICE MANUALS - CD VERSION)	500.00
11. HDTCM (HD TCM-135-DHE PATCHER)	58,828.00
TOTAL	\$ 123,580.00

NON CONTRACT OPTION:	
1. 425-160 DHE (SPECIFIED AS PER QUOTE)	DEDUCT <\$ 3,200.00>
TOTAL COST	\$ 120,380.00

Approved by Seller:

Accepted by Purchaser:

Official Title and Date

Firm or Business Name

Authorized Signature

Authorized Signature and Date

This proposal is not binding upon the seller
without Seller's Authorized Signature

Official Title and Date



H.D. INDUSTRIES, Inc.

Pro-Patch Pothole Patcher

P.O. BOX 8250 · JACKSONVILLE, TEXAS 75766 · (903) 586-6126 · www.pro-patch.com

February 28, 2007

Alan Beyer
Sun State International Trucks
6020 Adamo Drive
Tampa, FL 33619

Dear Alan:

Following is our quote to Sun State International for the **Pro-Patch** Model TCM 425-160-DHE as requested for Lee County, Florida.

1. Basic Unit Model TCM 425-160-DHE.....
2. Secondary Auger Motor
3. 30" Spoils Bin.....
4. Wacker WP1550AW Compactor Plate
5. Hydraulic Rear Lift Platform with Pavement Breaker Mount.....
6. Stanley BR45 Pavement Breaker
7. Hydraulic Bi-fold Steel Top Doors.....
8. Diesel Fuel Hose Reel with 20 Ft. Hose
9. 10 Gallon Drip & Waste Oil Tank
10. 8 Gallon Water Tank
11. 50 Gallon Frame Mounted LP Gas Bottle
12. Wanco WSBA-14 Arrow Board
13. Meteorlight SY2000 Strobe Light
14. PTO.....
15. Electronic Engine Throttle Control.....
16. Delivery & Three (3) Days Training

.....

Delivery to be 180 - 220 days after receiving the purchase order.

If you have any questions, please give me a call at 1-800-256-6126.

Thank you,

Harold Dillingham

Harold Dillingham
President



Pro-Patch

THE YEAR 'ROUND ECONOMICAL SOLUTION TO ASPHALT STREET PROBLEMS

- Home Page
- Company
- Truck Mounted - Heat Transfer Oil System
- Truck Mounted - Dry Radiant Heat System
- Trailer Mounted Units
- All Electric Units
- Options
- Authorized Dealers
- Contact Us

Truck Options

WORK DECK

Available on units with a built-on road oil tank. The work deck is constructed of 1/4" angle iron and 3/16" expanded metal with assist hand rails. The work deck is mounted between the hopper and the truck cab. The work deck provides easy and safe access to the emulsion oil tank and asphalt hopper from the passenger side.



SPOILS BIN

The spoils bin is 30" wide with a 1.25 cubic yard capacity and features a gravity dump. Asphalt spoils may be loaded or discharged from both sides of the truck.

VIBRATORY COMPACTOR PLATE

A Wacker WP 1550AW compactor equipped with a 5.5 hp gasoline Honda engine with auto oil alarm shut down. Operating weight is 190 lbs, centrifugal force is 3375 lbs, plate size is 19.5" x 23". Also features a water tank and locking holding brackets.

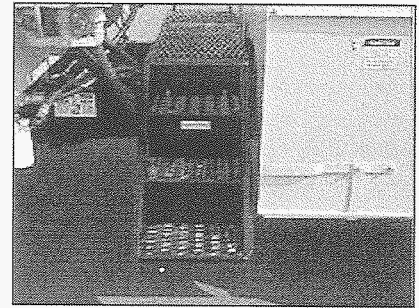

VIBRATORY ROLLER

The vibratory roller is a Bomag BW55E with a 4 hp Honda engine. Operating weight is 351 lbs, centrifugal force is 2250 lbs, single drum vibratory roller is 22" wide. Also features a centrifugal clutch and water tank.

HYDRAULIC REAR LIFT PLATFORM

A hydraulically operated lift platform for loading or unloading a compactor plate or roller. The platform has a safety latch in the "up" position, an in-cab "platform down" indicator light with compactor or roller holding brackets. The platform also has an optional pavement breaker mount. All controls for the platform are at the rear of the unit.

ELECTRIC HOIST

A 12 volt 1 1/3 hp electric hoist is available for loading or unloading the vibratory compactor plate.

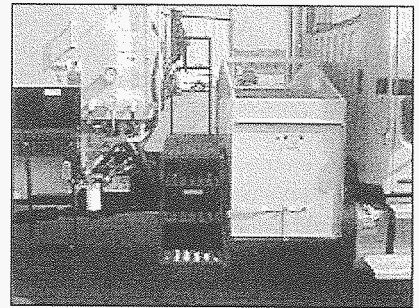

PAVEMENT BREAKERS

Optional equipment: Stanley BR45, 72, 67 and 87 pavement breakers, complete with quick couplers, asphalt cutter, tamper and detachable shank with lockable transporting bracket.

BR 45

HYDRAULIC TOOL LINE HOSE REEL

Hose pressure is 3000 PSI with dual 25' hydraulic tool lines. Comes with spring loaded auto retractable reel.

HYDRAULIC OPERATED STEEL TOP DOORS

Two hydraulically operated bi-fold steel top doors that come with hex brake for rigidity. Doors are insulated with 2" of high temperature insulation in a double steel jacket. The doors have rain seal caps and flex plates to keep asphalt out of the door hinges. Each door has a 1 1/2" bore with a 13" stroke hydraulic cylinder with bypass and flow control valves. The controls for the doors are at the front of the unit behind the passenger side of the truck cab.

INSULATED TARP TOP COVER

The tarp is a double form fitted 2" insulated tarp with tie downs. The tarp material is capable of sustaining temperatures up to 500° F.

AIR LINE HOSE REEL

This comes with 20' of hose and a spring loaded, auto retractable reel.

HYDRAULIC AIR COMPRESSOR

This is used to blow out repair sight and other compressed air demands. The hydraulically driven air compressor is self contained, and operates at 25 CFM @ 125 PSI, and comes with a cooling fan. The air compressor also comes with quick couplers, 20' of air hose, a 5' air blow gun with deadman control valve, a 5 gallon air tank with cable assisted condensation drain and 150 PSI relief valve. Hydraulic and electric controls are located at the right rear of the unit.



DIESEL FUEL HOSE REEL

This is used for the diesel fuel spray wand. It comes with 20' of hose and a spring loaded, auto retractable reel.

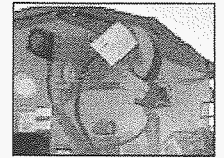

TACK OIL HOSE REEL

This comes with 15' of hose and a spring loaded, auto retractable reel.



DRIP PAN

A ten gallon drip pan, unit mounted, that is used for waste oil.



WATER TANK

A frame mounted, eight gallon tank with valve and hose. Provides a water supply for the asphalt compactor plate. Comes with rust proof liner.

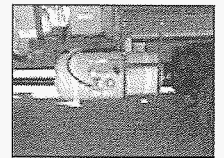

need
50 gallon



FRAME MOUNTED LP GAS BOTTLE

A frame mounted 35 gallon or 50 gallon capacity LP gas bottle with quick fill connector, 10 PSI regulator and fuel sight gauge.

need 50 gal

FUEL

A 100 lb (25 gallon) removable propane bottle, complete with 10 PSI regulator valve.



DIRECTIONAL ARROW BOARD

Available arrow board is an Able II with lights that flash left, right and warning bar. The board is mounted on the rear of the Pro-Patch unit with in-cab controls.



DIRECTIONAL ARROW BOARD

Available arrow board is a Wanco model WSBA-14 with 14 seal beams. This state DOT approved arrow board flashes left, right and warning bar. The board is mounted on the rear of the Pro-Patch unit with in-cab controls.



STROBE LIGHT

A pedestal mounted Meteorlight SY2000.

SAND SPREADER ASSEMBLY

The sand spreader assembly includes chute, spinner, hydraulic motor, hydraulic lines and all quick coupler connecting fittings. In-cab controls.



EXTRA TOOL BOX

A 12 gauge steel 19" x 24" 30" tool box with waterproof locking door.

ASPHALT EDGER

The edger is designed to repair deteriorated shoulders on a highway. The screw conveyor assembly is ball bearing mounted. The conveyor is driven by a hydraulic motor with forward and reverse capabilities. The edger is powered by a 20 hp Honda LP gas or gasoline engine with direct mounted hydraulic pump. The unit mounts to the rear of the Pro-Patch unit with four bolts. Also comes with a separate asphalt chute. A hydraulic splitter valve allows separate control from the hopper screw conveyor to the side deliver screw conveyor. The screw conveyor is fully enclosed for safety. The asphalt edger is also available with an optional 21 hp Lombardini air cooled diesel engine with electric start and low oil shut down.



PTO

A Muncie or Chelsea PTO electric over air shift or hot shift, depending on the truck's transmission model.



THROTTLE CONTROL

A rear mounted electronic engine throttle control.

THROTTLE CONTROL FOR MANUAL TRANSMISSIONS

Patch truck



FLORIDA SHERIFFS ASSOCIATION, FLORIDA ASSOCIATION OF COUNTIES & FLORIDA FIRE CHIEFS' ASSOCIATION

30,000 LB. GVWR CAB & CHASSIS (DUAL REAR WHEEL) - 4X2 SPECIFICATION #47

2007/2008 International 4300V SBA (MA015)

The International 4300V SBA (MA015) purchased through this contract comes with all the standard equipment as specified by the manufacturer for this model and FSA's base vehicle specification(s) requirements which are included and made a part of this contract's vehicle base price as awarded by specification by zone.

ZONE:	Western	Northern	Central	Southern
BASE PRICE:	\$41,300.00	\$41,600.00	\$41,300.00	\$41,600.00

While the Florida Sheriffs Association, Florida Association of Counties and Florida Fire Chiefs' Association have attempted to identify and include those equipment items most often requested by participating agencies for full size vehicles, we realize equipment needs and preferences are going to vary from agency to agency. In an effort to incorporate flexibility into our program, we have created specific add/delete options which allow the purchaser to tailor the vehicle to their particular wants or needs.





The following equipment delete and add options and their related cost are provided here to assist you in approximating the total cost of the type vehicle(s) you wish to order through this program. Simply deduct the cost of any of the following equipment items you wish deleted from the base unit cost and/or add the cost of any equipment items you wish added to the base unit cost to determine the approximate cost of the type vehicle(s) you wish to order.

NOTE: An official listing of all add/delete options and their prices should be obtained from the appropriate dealer in your zone when preparing your order. Additional add/delete options other than those listed here may be available through the dealers, however, those listed here must be honored by the dealers in your zone at the stated prices.

would prefer Pro-Patch model = TCM 425-160-DHE
with attached options

VEHICLE:	4300V SBA (MA015)	4300V SBA (MA015)	4300V SBA (MA015)	4300V SBA (MA015)
DEALER:	Sun State International Trucks, LLC	Sun State International Trucks, LLC	Sun State International Trucks, LLC	Sun State International Trucks, LLC
ZONE:	Western	Northern	Central	Southern 
BASE PRICE:	\$41,300.00	\$41,600.00	\$41,300.00	\$41,600.00

Order Code	Delete Options	All Zones
13NGG ¹	Provide 6 speed manual with base engine (specify) <i>Fuller FS-5406N</i> ¹	\$1,700.00 ¹
	Provide 7 speed manual with base engine (specify)	NA
	Air brakes if compatible with transmission	NA
D29580 ¹	Wheel seals	\$18.00 ¹
D8REY ¹	AM/FM stereo radio	\$200.00 ¹
	Passenger air bag	NA
	Daytime running lights	NA

Order Code	Add Options	All Zones
12NSM ¹	Engine/transmisison upgrade (specify) <i>Maxxforce DT 225 HP 2500RDS Trans.</i> ¹	\$5,200.00 ¹
12NSG ¹	Engine/transmisison upgrade (specify) <i>Maxxforce DT 245 HP 2500RDS Trans.</i> ¹	\$6,200.00 ¹
	Engine hour meter	Std
	Trans oil temp meter	Incl.
13WLE ¹	Allison authorized synthetic oil, TES 295 or equivalent (required for extended warranty)	\$160.00 ¹ 
	Premium hoses	NA
15DMN ¹	Dual 45 gallon fuel tanks <i>Dual 50 Gal.</i> ¹	\$498.00 ¹
4EBD ¹	Air dryers <i>Bendix AD-IP</i> ¹	\$537.00 ¹ 
4722 ¹	Moisture ejectors <i>Automatic heated ejectors</i> ¹	\$140.00 ¹ 
	Power windows, only	NA
16WJU ¹	Power windows/door locks	\$386.00 ¹
	Speed control	Std
5798 ¹	Tilt steering wheel	\$130.00 ¹
	Telescopic and tilt steering wheel	NA
8GRP ¹	AM/FM radio with single CD	\$180.00 ¹ 
	Side air bags	NA
3K ¹	Third key	\$10.00 ¹ 
4X4 ¹	Upgrade to 4x4 (specify factory or after market) <i>Factory - Base Bid Specifications</i> ¹	\$19,700.00 ¹
	Upgrade to Sterling L model	NA

VEHICLE:	4300V SBA (MA015)	4300V SBA (MA015)	4300V SBA (MA015)	4300V SBA (MA015)
DEALER:	Sun State International Trucks, LLC	Sun State International Trucks, LLC	Sun State International Trucks, LLC	Sun State International Trucks, LLC
ZONE:	Western	Northern	Central	Southern
BASE PRICE:	\$41,300.00	\$41,600.00	\$41,300.00	\$41,600.00

16196 ¹	Crew cab (84" CA) <i>Changes seats to Front & Rear Benchs¹</i>	\$8,254.00 ¹	
16CAB ¹	Super cab (84" CA) <i>Extended Cab - No rear seat¹</i>	\$2,647.00 ¹	
	Cutaway cab	NA	
VENT ¹	Vent visors - stick-on style	\$150.00 ¹	
RSF ¹	Rainshields - flange style	\$150.00 ¹	
LINER ¹	Spray-in liner (Rhino or approved equivalent) <i>Rhino¹</i>	\$990.00 ¹	
TBOX ¹	Knapheide under body tool boxes or approved equivalent <i>48¹</i>	\$600.00 ¹	
16WSL ¹	Fender or cowl mounted convex mirrors <i>Hood Mounted Rt. & Lt. Mirrors¹</i>	\$142.00 ¹	
8WCL ¹	Airhorn <i>Single Trumpet¹</i>	\$50.00 ¹	★
SAFETY ¹	Safety kit, fire extinguishers & triangles <i>INSTALLED IN CAB¹</i>	\$100.00 ¹	★
	Front stabilizer bars	NA	
14WAP ¹	Rear shock absorbers	\$96.00 ¹	
	Auxiliary rear springs	Incl.	
15LKE ¹	Heated fuel water separator	\$152.00 ¹	
FLAP ¹	Mud flaps <i>Internationaal Logo¹</i>	\$50.00 ¹	
SPARE ¹	Full size spare tire & rim <i>22.5¹</i>	\$898.00 ¹	
	Jack and wheel wrench	NA	
11SB ¹	Knapheide 6132 utility body or approved equivalent (requires 84" CA)	\$10,996.00 ¹	
3YD ¹	Heil 2-3 yd. dump body with manual tarp or approved equivalent (requires 84" CA)	\$9,625.00 ¹	
5YD ¹	10 ft. 5 yd. dump with manual tarp (requires 84" CA)	\$9,925.00 ¹	
12STK ¹	12 ft. flat stake body (requires 84" CA)	\$4,825.00 ¹	
12CD ¹	12 ft. contractors dump with manual tarp (requires 84" CA)	\$8,735.00 ¹	
14STK ¹	14 ft. flat stake body (requires 108" CA) <i>Reqs. Code 108CA Addn'l \$1559¹</i>	\$4,935.00 ¹	
14CD ¹	14 ft. contractors dump with manual tarp (requires 108" CA) <i>Reqs. Code 108CA Addn'l \$1559¹</i>	\$9,860.00 ¹	
16STK ¹	16 ft. flat stake body (requires 120" CA) <i>Reqs. Code 120CA Addn'l \$2641¹</i>	\$5,280.00 ¹	
16CD ¹	16 ft. contractors dump with manual tarp (requires 120" CA) <i>Reqs. Code 120CA Addn'l \$2641¹</i>	\$9,800.00 ¹	

VEHICLE:	4300V SBA (MA015)	4300V SBA (MA015)	4300V SBA (MA015)	4300V SBA (MA015)
DEALER:	Sun State International Trucks, LLC	Sun State International Trucks, LLC	Sun State International Trucks, LLC	Sun State International Trucks, LLC
ZONE:	Western	Northern	Central	Southern
BASE PRICE:	\$41,300.00	\$41,600.00	\$41,300.00	\$41,600.00

18STK ¹	18 ft. flat stake body (requires 138" CA) <i>Reqs. Code 138CA Addn'l \$2841¹</i>	\$5,580.00 ¹
	19 ft. rollback wrecker with wheel lift (requires 120" CA)	NA
20STK ¹	20 ft. flat stake body (requires 156" CA) <i>Reqs. Code 156CA Addn'l \$2891¹</i>	\$5,920.00 ¹
VA20 ¹	20 ft. van roll up door (requires 156" CA) <i>Reqs. Code 156CA Addn'l \$2891¹</i>	\$7,272.00 ¹
VA24 ¹	24 ft. van roll up door (requires 186" CA) <i>Reqs. Code 186CA Addn'l \$3041¹</i>	\$7,545.00 ¹
24STK ¹	24 ft. flat stake body (requires 186" CA) <i>Reqs. Code 186CA Addn'l \$3041¹</i>	\$6,920.00 ¹
HDTCM ¹	24 ft. van roll up door (requires 186" CA) Optional body (specify) <i>HD Industries TCM-425-135 Pothole Patcher¹</i> <i>manuels</i>	NA \$58,828.00 ¹
TL3 ¹	Optional body (specify) <i>Petersen Loader with 1824 body - Reqs. Code 156CA Addn'l \$2891¹</i>	\$42,800.00 ¹
TL50P ¹	Optional body (specify) <i>Terex TL50P Aerial Device - Reqs. Code 138CA Addn'l \$2841¹</i>	\$67,075.00 ¹
108CA ¹	108" cab to axle	\$1,559.00 ¹
120CA ¹	120" cab to axle	\$2,641.00 ¹
138CA ¹	138" cab to axle	\$2,841.00 ¹
156CA ¹	156" cab to axle	\$2,891.00 ¹
180CA ¹	180" cab to axle	\$2,900.00 ¹
186CA ¹	186" cab to axle	\$3,041.00 ¹
4080-03 ¹	33,000 GVWR Pck. - minimum 230 HP, 5 speed automatic transmission (3000RDS), or approved equivalent - see optional wheelbase prices <i>Maxxforce DT 245 HP 3000RDS¹</i>	\$10,400.00 ¹
4082-01 ¹	33,000 GVWR Pck. - minimum 230 HP, 5 speed automatic transmission (3500RDS), or approved equivalent - see optional wheelbase prices <i>Maxxforce DT 260 HP 3500RDS¹</i>	\$12,400.00 ¹
4082-02 ¹	33,000 GVWR Pck. - minimum 230 HP, 6 speed automatic transmission (3000RDS), or approved equivalent - see optional wheelbase prices <i>Maxxforce DT 285 HP 3000RDS¹</i>	\$12,700.00 ¹
4082-3 ¹	33,000 GVWR Pck. - minimum 230 HP, 6 speed automatic transmission (3500RDS), or approved equivalent - see optional wheelbase prices <i>Maxxforce DT 285 HP 3000RDS 35,000 GVW¹</i>	\$13,100.00 ¹
7300 ¹	33,000 GVWR factory approved 4WD <i>Maxxforce DT 225 HP 2500RDS¹</i>	\$29,400.00 ¹
108CAG ¹	33,000 GVWR 108" CA	\$1,559.00 ¹
120CAG ¹	33,000 GVWR 120" CA	\$2,641.00 ¹

*Model TCM 425-160-DHE
want 160 gal*

★

Bucket truck?

Bucket truck?

VEHICLE:	4300V SBA (MA015)	4300V SBA (MA015)	4300V SBA (MA015)	4300V SBA (MA015)
DEALER:	Sun State International Trucks, LLC	Sun State International Trucks, LLC	Sun State International Trucks, LLC	Sun State International Trucks, LLC
ZONE:	Western	Northern	Central	Southern
BASE PRICE:	\$41,300.00	\$41,600.00	\$41,300.00	\$41,600.00

156CAG ¹	33,000 GVWR 156" CA	\$2,891.00 ¹
180CAG ¹	33,000 GVWR 180" CA	\$2,900.00 ¹
186CAG ¹	33,000 GVWR 186" CA	\$3,041.00 ¹
2KLG ¹	2,000 lb. lift gate	\$4,270.00 ¹
3KLG ¹	3,000 lb. lift gate	\$8,700.00 ¹
	12 jon jack cab mounted, if available	NA
50K22 ¹	Auto Crane 50K-22 crane body with shelf package, 24" bumper with crank outriggers, or approved equivalent	\$16,412.00 ¹
6006 ¹	Auto Crane 6006EH electric hydraulic crane, boom support & chassis springs, or approved equivalent	\$19,100.00 ¹
OUT ¹	Auto Crane hydraulic outriggers, or approved equivalent	\$2,600.00 ¹
6406 ¹	Auto Crane 6406 hydraulic crane, reservoir, PTO and pump, boom supprt & chassis springs, or approved equivalent	\$21,653.00 ¹
8406 ¹	Auto Crane 8406 hydraulic crane, reservoir, PTO and pump, boom supprt & chassis springs	\$24,460.00 ¹
ALARM ¹	Backup alarm	\$120.00 ¹ ★
BUC ¹	Backup camera with 3.5' LCD (rear mounted camera to provide wide angle field of vision at rear of vehicle)	\$1,000.00 ¹
	Left-hand pillar mounted 6" spotlight with clear halogen bulb	NA
	Left & right-hand pillar mounted 6" spotlight with clear halogen bulb	NA
SGL ¹	Strobe grille lights, 2 minimum (Whelen, Federal, Code 3 or approved equivalent)	\$680.00 ¹
LED ¹	LED, GEN 3 minimum, grille lights, 2 minimum - LED lights may be blue, red, amber or any combination - specify color (Whelen, Federal, Code 3 or approved equivalent)	\$800.00 ¹
RMS ¹	Rearview mirror strobes (Whelen, Federal, Code 3 or approved equivalent)	\$640.00 ¹
	LED, GEN 3 minimum, external mirror flashing lights - LED lights may be blue, red, amber or any combination - specify color (Whelen, Federal, Code 3 or approved equivalent)	NA
RMAS ¹	Roof-mount amber strobe beacon (Whelen, Federal, Code 3 or approved equivalent)	\$330.00 ¹
	Strobe integral directional arrow activated in lightbar (with controller if required). Requires purchase of lightbar.	NA
	LED, GEN 3 minimum, integral directional arrow activated in lightbar (with controller if required) - LED lights may be blue, red, amber or any combination - specify color. Requires purchase of lightbar.	NA
	Halogen integral directional arrow added to lightbar (with controller if required)	NA
	Traffic directional LED, GEN 3 minimum, arrow with 6 modules (with controller if required).	NA
	Code 3 RLS - upgrade, deluxe siren, microprocessor controlled	NA
	Federal Signal Smart Siren - upgrade, deluxe siren, microprocessor controlled	NA
	Whelen Cencom - upgrade, deluxe siren, microprocessor controlled	NA
	Code 3 - Headlight flashers, solid state	NA
	Federal Signal - Headlight flashers, solid state	NA

VEHICLE:	4300V SBA (MA015)	4300V SBA (MA015)	4300V SBA (MA015)	4300V SBA (MA015)
DEALER:	Sun State International Trucks, LLC	Sun State International Trucks, LLC	Sun State International Trucks, LLC	Sun State International Trucks, LLC
ZONE:	Western	Northern	Central	Southern
BASE PRICE:	\$41,300.00	\$41,600.00	\$41,300.00	\$41,600.00

	Whelen - Headlight flashers, solid state	NA
	Upgrade basic (6) switch controller and siren to combination light controller/siren	NA
CSP60 ¹	Corner Strobe Kits – Whelen Kit with 4 clear tubes, 6 outlet CSP 60w power supply, 2-15' cables, 2-30' cables	\$770.00 ¹
CSP90 ¹	Corner Strobe Kits – Whelen Kit with 4 clear tubes, 6 outlet CSP 90w power supply, 2-15' cables, 2-30' cables	\$790.00 ¹
CSFK ¹	Corner Strobe Kits – Federal Kit with 4 clear tubes, 6 outlet 660L power supply, 2-15' cables, 2-30' cables	\$870.00 ¹
CSRICH ¹	Corner Strobe Kits – Federal Kit with 4 clear tubes, 6 outlet RICHOCHET power supply, 2-15' cables, 2-30' cables	\$890.00 ¹
	Corner Strobe Kits – Soundoff Kit with 4 clear tubes, 6 outlet, 60w Nebula power supply, 2-15', 2-30' cables	NA
	Corner Strobe Kits – Soundoff Kit with 4 clear tubes, 6 outlet, 110w Gemini power supply, 2-15', 2-30' cables	NA
	Corner Strobe Kits – Code 3 Kit with 4 clear tubes, PSE460 power supply, 2-15' cables, 2-30' cables	NA
	Corner Strobe Kits – Code 3 Kit with 6 clear tubes, PSE690 power supply, 2-15' cables, 2-30' cables	NA
	Optional equipment (specify)	NA
	Optional equipment (specify)	NA
	Optional equipment (specify)	NA
	Optional equipment (specify)	NA
DSM ¹	Complete set of shop manuals ONLY <i>CD Version</i> ¹	\$500.00 ¹
B1012C ¹	Minimum 5/75 Manufacturer's Extended Base Warranty (\$0 deductible) <i>See Policy for Coverages</i> ¹	\$1,940.00 ¹

need manuals for patcher (pro patch) and truck ←



FLORIDA SHERIFFS ASSOCIATION, FLORIDA ASSOCIATION OF COUNTIES & FLORIDA FIRE CHIEFS' ASSOCIATION

30,000 LB. GVWR CAB & CHASSIS (DUAL REAR WHEEL) - 4X2 SPECIFICATION #47

2007/2008 Ford F-750 (F75)
2007/2008 Chevrolet CC7500 (CC7C042)
2007/2008 GMC TC7500 (TC7C042)
2007/2008 Freightliner M2
2007/2008 Hino 338
2007/2008 International 4300V SBA (MA015)
2007/2008 Isuzu H7500 (JC7C042)
2007/2008 Kenworth T300
2007/2008 Peterbilt 335
2007/2008 Sterling Acterra

ALL ITEMS FACTORY INSTALLED UNLESS OTHERWISE INDICATED

INSTRUCTIONS: Listed above, you will find the model numbers of the vehicles that will be included in this year's contract.

1. ENGINE:

- a. Diesel engine, minimum 200 HP - must meet 2007 emission standards.

2. TRANSMISSION/AXLES:

- a. Allison 2500 RDS transmission (with PTO provision) minimum, or approved equivalent.
- b. 21,000 lb. rear
- c. All axles, synthetic lube.

3. PERFORMANCE ITEMS:

- a. Manufacturer's standard power steering.
- b. Manufacturer's standard gauges.

4. COMFORT ITEMS:

- a. Air conditioning, factory installed.
- b. Manufacturer's standard tinted glass all around.
- c. Manufacturer's standard AM/FM stereo.
- d. Heavy duty rubber floor covering instead of carpet.
- e. Manufacturer's standard production seats. Purchaser will select color at time of order.
- f. Keys: two (2) per vehicle, single key locking system, (each vehicle keyed differently).

5. SAFETY ITEMS:

- a. Dual mount outside mirrors to provide field of vision for vehicles to 102" wide.
- b. Convex mirrors mounted below standard mirrors.
- c. Interior dome lights with left and right door activated switches.
- d. Air bags for driver and right front passenger, if available.
- e. Minimum 2 speed electric wipers with wet arm washers.
- f. Daytime running lights, if available.

6. BRAKES:

- a. Factory air brakes, anti-lock, slack adjusters and dust shields.

7. TIRES AND WHEELS:

- a. BSW 11R22.5 (14 PR) Goodyear G149, or approved equivalent, front and rear.
- b. Front wheel seals, synthetic lube.

8. CHASSIS, FRAME, CAB:

- a. Minimum 30,000 lbs. GVWR.
- b. Cab & chassis only.
- c. Manufacturer's standard colors, factory painted. Colors to be determined by individual agencies.
- d. Front bumper, bright or painted.
- e. Factory front tow hooks.
- f. Fuel tank capacity, 45 gallons minimum.
- g. Cab to center of rear axle - 84" approximately.

9. CONDITIONS

In addition to equipment specified, vehicle shall be equipped with all standard equipment as specified by the manufacturer for this model and shall comply with all EPA Emission Standards and all Motor Vehicle Safety Standards as established by the U.S. Department of Transportation regarding the manufacture of motor vehicles.

The successful bidder shall be responsible for delivering vehicles that are properly serviced, clean and in first class operating condition. Pre-delivery service, at a minimum, shall include the following:

- a. Complete lubrication.
- b. Check all fluid levels to assure proper fill.
- c. Adjustment of engine to proper operating condition.
- d. Inflate tires to proper pressure.
- e. Check to assure proper operation of all accessories, gauges, lights, and mechanical features.
- f. Focusing of headlights.
- g. Cleaning of vehicles, if necessary, and removal of all unnecessary tags, stickers, papers, etc. **DO NOT** remove window price sticker or supplied line sheet.

**BID AWARD
ANNOUNCEMENT**

06-14-0821A

**PURSUIT,
ADMINISTRATIVE NON-PURSUIT,
UTILITY VEHICLES, TRUCKS & VANS,
& OTHER FLEET EQUIPMENT**

*Participating Sheriff's Offices & Local Governmental
Agencies of the State of Florida*

Coordinated By

The

**Florida Sheriffs Association,
Florida Association of Counties &
Florida Fire Chiefs' Association**



TABLE OF CONTENTS

ORDERING INSTRUCTIONS	6
Overview of Awarded Specifications	7
Awarded Dealers	13
Basic Information REQUIRED for Purchase Orders	16
District Map	17

SPECIFICATIONS 1-45 AND 51-60 WERE AWARDED ON BID 06-14-0821

- Specification #1 – Full Size Vehicles - RWD (Police Package)
- Specification #2 – Full Size Vehicles - FWD (Police Package)
- Specification #3 – Full Size Utility Vehicles - RWD (Police Package)
- Specification #4 – Full Size 4-Door Administrative Vehicles
- Specification #5 – Mid Size 4-Door Administrative Vehicles
- Specification #6 – Compact 4-Door Administrative Vehicles
- Specification #7 – Hybrid 4-Door Administrative Vehicles
- Specification #8 – Small 4 Passenger Electric Vehicle
- Specification #9 – Off-Road Utility Vehicle
- Specification #10 – Police Motorcycle
- Specification #11 – Motorcycle
- Specification #12 – Hybrid Small Size 4-Door Utility Vehicles - FWD
- Specification #13 – Hybrid Small Size 4-Door Utility Vehicles - 4x4
- Specification #14 – Small Size 4-Door Utility Vehicles - 4x2
- Specification #15 – Small Size 4-Door Utility Vehicles - 4x4 or AWD
- Specification #16 – Mid Size 4-Door Utility Vehicles - 4x2
- Specification #17 – Mid Size 4-Door Utility Vehicles - 4x4
- Specification #18 – Full Size 4-Door Utility Vehicles - 4x2
- Specification #19 – Full Size 4-Door Utility Vehicles - 4x4
- Specification #20 – 1/2 Ton 4-Door Extended Wheelbase Utility Vehicles - 4x2
- Specification #21 – 1/2 Ton 4-Door Extended Wheelbase Utility Vehicles - 4x4
- Specification #22 – 3/4 Ton 4-Door Extended Wheelbase Utility Vehicles - 4x2
- Specification #23 – 3/4 Ton 4-Door Extended Wheelbase Utility Vehicles - 4x4
- Specification #24 – 7 Passenger Mini Van - FWD
- Specification #25 – 8 Passenger Van - RWD
- Specification #26 – 12 Passenger Van
- Specification #27 – 15 Passenger Van
- Specification #28 – Utility Cargo Van
- Specification #29 – Compact Pickup Truck - 4x2
- Specification #30 – Compact Pickup Truck - 4x4
- Specification #31 & #32 – Hybrid 1/2 Ton Extended Cab Pickup Truck
- Specification #33 – 1/2 Ton Pickup Truck - 4x2
- Specification #34 – 1/2 Ton Pickup Truck - 4x4
- Specification #35 – 3/4 Ton Pickup Truck - 4x2
- Specification #36 – 3/4 Ton Pickup Truck - 4x4

Specification #49 – 52,000 lb. GVWR Cab & Chassis 4x6 Tandem Axle Truck <i>(continued)</i>	
Freightliner M2-112	173
International 7600	176
Kenworth T800	179
Mack C or G Series	183
Peterbilt 367	187
Sterling L Series	190
Volvo V Series	193
Western Star 4900	197

Specification #50 – 60,000 lb. GVWR Cab & Chassis 4x6 Tandem Axle Refuse Truck	
Awarded Dealer(s)	200
Base Specifications	201
American LaFrance Condor	203
Autocar WX64	206
Crane Carrier LET2	210
Mack MR Series	213
Peterbilt 320	217

- Specification #51 – 4x4 Loader Backhoe with Canopy (Standard Stick)
- Specification #52 – 3.0 Cu. Yd. Wheel Loader (Z-Bar Linkage Bucket - Parallel Arm Option)
- Specification #53 – Motorgrader
- Specification #54 – Agriculture Type Tractor (2 Wheel Drive)
- Specification #55 – Agriculture Type Tractor with Optional Boom Mower (2 Wheel Drive)
- Specification #56 – 70 HP Track Type Canopy Tractor (Standard Track - Wide Track Optional)
- Specification #57 – 90 HP Track Type Canopy Tractor (Standard Track - Wide Track Optional)
- Specification #58 – Skid Steer Loader - 1850 lb. Operating Capacity
- Specification #59 – 15 ft. Flex Wind Rotary Mower - PTO Driven
- Specification #60 – Regenerative Air Street Sweeper

Manufacturer’s Extended Vehicle Warranty	220
Mears Motor Leasing	222

MEMO



FLORIDA SHERIFFS ASSOCIATION

P. O. Box 12519 • Tallahassee, FL 32317-2519
PHONE (850) 877-2165 • FAX (850) 878-8665
WEB SITE: <http://www.flsheriffs.org>

DATE: January 1, 2007

TO: **ALL PROSPECTIVE PARTICIPANTS**

FROM: Gary E. Perkins Lynn Meek Peggy Goff
Executive Director Vehicle Bid Coordinator Vehicle Contract Manager

RE: **SHERIFFS' OFFICES & LOCAL GOVERNMENTAL AGENCIES
OF THE STATE OF FLORIDA COOPERATIVE BID FOR
PURSUIT, ADMINISTRATIVE NON-PURSUIT, UTILITY VEHICLES,
TRUCK & VANS, & OTHER FLEET EQUIPMENT
Bid No. 06-14-0821A**

We are pleased to announce that the Florida Sheriffs Association, Florida Association of Counties and Florida Fire Chiefs' Association has successfully conducted its statewide competitive bid for the trucks which were not awarded in Bid 06-14-0821. This contract is effective beginning January 1, 2007 through September 30, 2007, as long as vehicles are available through fleet.

Bids will be extended and guaranteed to any and all units of local governments and political subdivisions including, but not limited to, county, local county board of public instruction, municipalities and/or police agencies, other local public or public safety agencies or authorities within the State of Florida. Also, in accordance with the provisions of Chapter 287, F.S., and 60A, Florida Administrative Code, any state agency including the Division of Universities, Department of Children and Family Services, Department of Health, Department of Juvenile Justice and Department of Corrections which elects and is authorized to purchase from a source other than the State of Florida contract is eligible to purchase from this bid.

In addition to the eligible users referenced above and with the consent of the successful bidder(s), purchases may be made under the terms and conditions of this contract by governmental entities located outside the State of Florida. Appropriate governmental entities' purchasing laws, rules and regulations shall apply to purchases made under this contract.

This program is designed to provide participating agencies with the most economically priced trucks, and other fleet equipment tailored to their specific needs, in a prompt and timely manner. One of the unique characteristics of this program that distinguishes it from others is that this bid contract is awarded to the lowest responsible bidder *by manufacturer* by specification by zone for all vehicles, trucks, vans and other fleet equipment.

The Florida Sheriffs Association, Florida Association of Counties and Florida Fire Chiefs' Association realize that Sheriffs' Offices, Police Agencies and other units of local governments must provide economically based maintenance and stocked parts for their fleets. They must consider overall operational cost of their vehicles instead of just considering "low bid" on the purchase of the vehicle. This program's bid award system not only provides the purchaser with the means to make sound decisions on dedicated fleet needs, but also offers the convenience of shopping and purchasing from a single contract.

All interested parties who wish to purchase from this contract may do so by following these simple procedures:

ORDERING INSTRUCTIONS

1. Contact the awarded dealership (see pages 13-14) listed in the zone from which you wish to purchase and advise them of your interest to purchase from the **Sheriffs' Offices & Local Governmental Agencies of the State of Florida Bid No. 06-14-0821A**. They will assist you with the placement of your order and answer any questions you may have regarding the vehicles purchased through this program.

All agencies ordering any FORD, GENERAL MOTORS, or CHRYSLER product, please be advised that you must use the appropriate FIN CODE/FAN CODE for the Florida Sheriffs Association in order to obtain the manufacturer's concessions. Also, you must use your FIN CODE/FAN CODE as a secondary number. For further assistance call the Fleet Customer Information Center for your appropriate manufacturer.

Manufacturer	Type Code	FSA Code	Fleet Center Contact Numbers	
FORD	FIN CODE	QE065	1-800-34-FLEET	(1-800-343-5338)
GENERAL MOTORS	FAN CODE	917872	1-800-FLEET OP	(1-800-353-3867)
DAIMLER CHRYSLER	FAN CODE	49313	1-800-999-FLEET	(1-800-999-3533)

2. **YOU MUST send a copy of the ORIGINAL PURCHASE ORDER (including FSA's Contract No. 06-14-0821A) you submitted to the participating dealer to:**

Florida Sheriffs Association
 P. O. Box 12519
 Tallahassee, Florida 32317-2519
 ATTN: Lynn Meek, Cooperative Bid Coordinator

3. **Basic information required on all purchase orders** is listed on Page 16 of this Bid Award Announcement. Purchase orders lacking the required basic information listed may result in the delay of placement and/or confirmation of orders. **NOTE:** Purchasers are reminded that the issuance of a Purchase Order does not in itself guarantee the placement of an order. The agency is responsible for filling in the requested information on the "Confirmation of Order" and submitting it along with your purchase order to the respective dealership. Dealers are required to fill in the bottom section of the "Confirmation of Order" and send it to the purchaser within seven (7) calendar days after receipt of purchase order. Purchasers are encouraged to contact the dealer if a "Confirmation of Order" has not been received within a reasonable time frame and request its issuance.
4. Agencies which elect to purchase off this contract will incur the following Administrative Fees:
 - **Pursuit, Administrative Non-Pursuit, Utility Vehicles, Trucks & Vans (Any vehicle up to 52,000 lb. GVWR)** – Dealers have included the administrative fee of \$75.00 per unit in their bid prices and made it a part of the base unit's purchase price.
 - **Trucks starting at 52,000 lb. GVWR and all Heavy Equipment** – Dealers are to charge purchasing agencies an administrative fee of 1/2 percent (.005) of the total invoice amount (base unit plus options) to be collected and paid to the FSA by the contracting dealers/manufacturer's. Administrative fees for trucks starting at 52,000 lbs. GVWR and all heavy equipment **will not** be included or made a part of the bidders base unit purchase price. This will be a separate line item on the agency's purchase order. The dealers/manufacturers will be responsible for calculating and advising the prospective purchasing agencies of the 1/2 percent (.005) administrative fee to be charged and included in the total invoice amount

at the time of order. The purchasing agencies will include the FSA administrative fee as a part of their purchase order request. Again, this will eliminate the need for purchasing agencies to have to prepare two separate purchase orders and checks.

5. In order to ensure quality service for our user agencies, we are requesting each of you to notify the Florida Sheriffs Association regarding any problems encountered in working with the awarded dealers. Any issues, including but not limited to, receipt of confirmation of order, delivery problems and communication problems, should be reported to us by e-mail at lmeeck@flsheriffs.com. This information will be considered in future bid awards in order to ensure that agencies are receiving the level of service required of dealers who wish to participate in this program.
6. Add/delete options might include a superscript listed by the Order Code. The purpose of the superscript is to identify which options correlate to a specific dealer. Superscripts will be a number between 1 and 4, and will correspond as follows:
 - 1 = Western zone dealer
 - 2 = Northern zone dealer
 - 3 = Central zone dealer
 - 4 = Southern zone dealer

If a dealer has been awarded more than one zone, they will only have one superscript number assigned, and it will be the lowest numerical number that applies to their awarded zones. For example, if a dealer is awarded the northern and southern zones, their add/delete options for both zones will be represented by a "2" superscript.

On a final note, prospective purchasers are reminded that pursuant to Florida State Statute all fees (title, application plate transfer, etc.) are included in the base price for each vehicle. Purchasing agencies which elect to do their own title work, may wish to consider seeking reimbursement from the dealership for those transfer fees already included in the base price of each vehicle.

The Florida Sheriffs Association's, Florida Association of Counties' and Florida Fire Chiefs' Association's bid award for full size (pursuit and administrative), mid size (pursuit and administrative), utility vehicles, trucks and vans, and other fleet equipment are as follows (zones indicated with a ★ = specification low bid):

Name of Dealership	Type of Vehicle	Zone	Base Price
25,500 LB. GVWR CAB & CHASSIS (DUAL REAR WHEEL) - 4X2 (Specification #46)			
Orville Beckford Ford-Mercury	Ford F-650 (F65)	Western	\$41,643.00
Atlantic Truck Center	Ford F-650 (F65)	Northern	\$39,756.00
Atlantic Truck Center	Ford F-650 (F65)	Central	\$39,756.00
Atlantic Truck Center	Ford F-650 (F65)	Southern	\$39,756.00
Classic Chevrolet Company	Chevrolet Kodiak 7500 (CC7C042)	Western	\$42,740.00
Classic Chevrolet Company	Chevrolet Kodiak 7500 (CC7C042)	Northern	\$42,850.00
Maroone Chevrolet, LLC	Chevrolet Kodiak 7500 (CC7C042)	Central	\$41,850.00
Maroone Chevrolet, LLC	Chevrolet Kodiak 7500 (CC7C042)	Southern	\$41,600.00
Nextran Truck Center - Tampa	GMC TC7500 (TC7C042)	Western	\$42,827.00
Nextran Truck Center - Tampa	GMC TC7500 (TC7C042)	Northern	\$42,627.00
Nextran Truck Center - Tampa	GMC TC7500 (TC7C042)	Central	\$42,627.00
Nextran Truck Center - Tampa	GMC TC7500 (TC7C042)	Southern	\$42,827.00

Name of Dealership	Type of Vehicle	Zone	Base Price
--------------------	-----------------	------	------------

25,500 LB. GVWR CAB & CHASSIS (DUAL REAR WHEEL) - 4X2 (Specification #46)
(continued)

Atlantic Truck Center	Freightliner M2	Western	\$39,775.00
Atlantic Truck Center	Freightliner M2	Northern	\$39,775.00
Atlantic Truck Center	Freightliner M2	Central	\$39,775.00
Atlantic Truck Center	Freightliner M2	Southern	\$39,775.00

	Hino 268A	Western	— NB —
Kenworth of Central Florida	Hino 268A	Northern	\$54,324.00
Kenworth of Central Florida	Hino 268A	Central	\$53,949.00
Kenworth of Central Florida	Hino 268A	Southern	\$54,324.00

Sun State International Trucks, LLC	International 4300V SBA (MA015)	Western	\$40,600.00
Sun State International Trucks, LLC	International 4300V SBA (MA015)	Northern	\$40,900.00
Sun State International Trucks, LLC	International 4300V SBA (MA015)	Central	\$40,600.00
Sun State International Trucks, LLC	International 4300V SBA (MA015)	Southern	\$40,900.00

	Kenworth T300	Western	— NB —
Kenworth of Central Florida	Kenworth T300	Northern	\$56,310.00
Kenworth of Central Florida	Kenworth T300	Central	\$55,935.00
Kenworth of Central Florida	Kenworth T300	Southern	\$56,310.00

Rush Truck Center - Tampa	Peterbilt 330	Western	\$51,708.00
Rush Truck Center - Tampa	Peterbilt 330	Northern	\$51,708.00
Rush Truck Center - Tampa	Peterbilt 330	Central	\$51,708.00
Rush Truck Center - Tampa	Peterbilt 330	Southern	\$51,708.00

Atlantic Truck Center	Sterling Acterra	★ Western	\$39,434.00
Atlantic Truck Center	Sterling Acterra	★ Northern	\$39,434.00
Atlantic Truck Center	Sterling Acterra	★ Central	\$39,434.00
Atlantic Truck Center	Sterling Acterra	★ Southern	\$39,434.00

30,000 LB. GVWR CAB & CHASSIS (DUAL REAR WHEEL) - 4X2 (Specification #47)

Orville Beckford Ford-Mercury	Ford F-750 (F75)	Western	\$41,543.00
Atlantic Truck Center	Ford F-750 (F75)	★ Northern	\$38,656.00
Atlantic Truck Center	Ford F-750 (F75)	★ Central	\$38,656.00
Atlantic Truck Center	Ford F-750 (F75)	★ Southern	\$38,656.00

Champion Chevrolet, Inc.	Chevrolet CC7500 (CC7C042)	Western	\$46,129.63
Champion Chevrolet, Inc.	Chevrolet CC7500 (CC7C042)	Northern	\$46,129.63
Maroone Chevrolet, LLC	Chevrolet CC7500 (CC7C042)	Central	\$42,900.00
Maroone Chevrolet, LLC	Chevrolet CC7500 (CC7C042)	Southern	\$42,650.00

Nextran Truck Center - Tampa	GMC TC7500 (TC7C042)	Western	\$43,587.00
Nextran Truck Center - Tampa	GMC TC7500 (TC7C042)	Northern	\$43,287.00
Nextran Truck Center - Tampa	GMC TC7500 (TC7C042)	Central	\$43,287.00
Nextran Truck Center - Tampa	GMC TC7500 (TC7C042)	Southern	\$43,487.00

Atlantic Truck Center	Freightliner M2	Western	\$39,514.00
Atlantic Truck Center	Freightliner M2	Northern	\$39,514.00

Name of Dealership	Type of Vehicle	Zone	Base Price
--------------------	-----------------	------	------------

30,000 LB. GVWR CAB & CHASSIS (DUAL REAR WHEEL) - 4X2 (Specification #47)
(continued)

Atlantic Truck Center	Freightliner M2	Central	\$39,514.00
Atlantic Truck Center	Freightliner M2	Southern	\$39,514.00
	Hino 338	Western	— NB —
Kenworth of Central Florida	Hino 338	Northern	\$58,720.00
Kenworth of Central Florida	Hino 338	Central	\$58,345.00
Kenworth of Central Florida	Hino 338	Southern	\$58,720.00
Sun State International Trucks, LLC	International 4300V SBA (MA015)	Western	\$41,300.00
Sun State International Trucks, LLC	International 4300V SBA (MA015)	Northern	\$41,600.00
Sun State International Trucks, LLC	International 4300V SBA (MA015)	Central	\$41,300.00
Sun State International Trucks, LLC	International 4300V SBA (MA015)	Southern	\$41,600.00
	Kenworth T300	Western	— NB —
Kenworth of Central Florida	Kenworth T300	Northern	\$60,235.00
Kenworth of Central Florida	Kenworth T300	Central	\$59,860.00
Kenworth of Central Florida	Kenworth T300	Southern	\$60,235.00
Rush Truck Center - Tampa	Peterbilt 335	Western	\$58,445.00
Rush Truck Center - Tampa	Peterbilt 335	Northern	\$58,445.00
Rush Truck Center - Tampa	Peterbilt 335	Central	\$58,445.00
Rush Truck Center - Tampa	Peterbilt 335	Southern	\$58,445.00
Atlantic Truck Center	Sterling Acterra	★ Western	\$39,120.00
Atlantic Truck Center	Sterling Acterra	Northern	\$39,120.00
Atlantic Truck Center	Sterling Acterra	Central	\$39,120.00
Atlantic Truck Center	Sterling Acterra	Southern	\$39,120.00

52,000 LB. GVWR CAB & CHASSIS - 4X6 TANDEM AXLE TRUCK TRACTOR (Specification #48)

	Autocar WX64	Western	— NB —
Kenworth of Central Florida	Autocar WX64	Northern	\$122,443.00
Kenworth of Central Florida	Autocar WX64	Central	\$122,068.00
	Autocar WX64	Southern	— NB —
Atlantic Truck Center	Freightliner M2-112	Western	\$63,071.00
Atlantic Truck Center	Freightliner M2-112	Northern	\$63,071.00
Atlantic Truck Center	Freightliner M2-112	Central	\$63,071.00
Atlantic Truck Center	Freightliner M2-112	Southern	\$63,071.00
Maudlin International Trucks	International 7600	Western	\$71,995.00
Maudlin International Trucks	International 7600	Northern	\$71,695.00
Maudlin International Trucks	International 7600	Central	\$71,495.00
Rechtien International Trucks, Inc.	International 7600	Southern	\$70,703.00
	Kenworth T800	Western	— NB —
Kenworth of Central Florida	Kenworth T800	Northern	\$81,855.00
Kenworth of Central Florida	Kenworth T800	Central	\$81,480.00
Kenworth of Central Florida	Kenworth T800	Southern	\$81,855.00

Name of Dealership	Type of Vehicle	Zone	Base Price
--------------------	-----------------	------	------------

52,000 LB. GVWR CAB & CHASSIS - 4X6 TANDEM AXLE TRUCK TRACTOR (Specification #48)

(continued)

Nextran Truck Center - Lake City	Mack C or G Series	Western	\$78,997.00
Nextran Truck Center - Lake City	Mack C or G Series	Northern	\$78,747.00
Nextran Truck Center - Tampa	Mack C or G Series	Central	\$78,747.00
Nextran Truck Center - Miami	Mack C or G Series	Southern	\$79,237.00
Rush Truck Center - Tampa	Peterbilt 367	Western	\$90,804.00
Rush Truck Center - Tampa	Peterbilt 367	Northern	\$90,804.00
Rush Truck Center - Tampa	Peterbilt 367	Central	\$90,804.00
Rush Truck Center - Tampa	Peterbilt 367	Southern	\$90,804.00
Atlantic Truck Center	Sterling LT9500	★ Western	\$62,471.00
Atlantic Truck Center	Sterling LT9500	★ Northern	\$62,471.00
Atlantic Truck Center	Sterling LT9500	★ Central	\$62,471.00
Atlantic Truck Center	Sterling LT9500	★ Southern	\$62,471.00
Nextran Truck Center - Lake City	Volvo V Series	Western	\$86,676.00
Nextran Truck Center - Lake City	Volvo V Series	Northern	\$86,426.00
Nextran Truck Center - Tampa	Volvo V Series	Central	\$86,427.00
General GMC Truck Sales & Service, Inc.	Volvo V Series	Southern	\$82,828.00
Heintzelman's Truck Center, Inc.	Western Star 4900	Western	\$81,178.00
Heintzelman's Truck Center, Inc.	Western Star 4900	Northern	\$81,178.00
Heintzelman's Truck Center, Inc.	Western Star 4900	Central	\$81,178.00
Heintzelman's Truck Center, Inc.	Western Star 4900	Southern	\$81,178.00

52,000 LB. GVWR CAB & CHASSIS - 4X6 TANDEM AXLE TRUCK (Specification #49)

Kenworth of Central Florida	Autocar WX64	Western	— NB —
	Autocar WX64	Northern	\$116,332.00
	Autocar WX64	Central	\$115,957.00
	Autocar WX64	Southern	— NB —
Atlantic Truck Center	Freightliner M2-112	Western	\$61,367.00
Atlantic Truck Center	Freightliner M2-112	Northern	\$61,367.00
Atlantic Truck Center	Freightliner M2-112	Central	\$61,367.00
Atlantic Truck Center	Freightliner M2-112	Southern	\$61,367.00
Sun State International Trucks, LLC	International 7600	Western	\$68,300.00
Sun State International Trucks, LLC	International 7600	Northern	\$68,600.00
Sun State International Trucks, LLC	International 7600	Central	\$68,300.00
Sun State International Trucks, LLC	International 7600	Southern	\$68,600.00
Kenworth of Central Florida	Kenworth T800	Western	— NB —
	Kenworth T800	Northern	\$82,234.00
	Kenworth T800	Central	\$81,859.00
	Kenworth T800	Southern	\$82,234.00
Nextran Truck Center - Lake City	Mack C or G Series	Western	\$85,897.00

Name of Dealership	Type of Vehicle	Zone	Base Price
--------------------	-----------------	------	------------

52,000 LB. GVWR CAB & CHASSIS - 4X6 TANDEM AXLE TRUCK (Specification #49)

(continued)

Nextran Truck Center - Lake City	Mack C or G Series	Northern	\$85,647.00
Nextran Truck Center - Tampa	Mack C or G Series	Central	\$85,647.00
Nextran Truck Center - Miami	Mack C or G Series	Southern	\$86,137.00
Rush Truck Center - Tampa	Peterbilt 367	Western	\$89,986.00
Rush Truck Center - Tampa	Peterbilt 367	Northern	\$89,986.00
Rush Truck Center - Tampa	Peterbilt 367	Central	\$89,986.00
Rush Truck Center - Tampa	Peterbilt 367	Southern	\$89,986.00
Atlantic Truck Center	Sterling L Series	★ Western	\$57,796.00
Atlantic Truck Center	Sterling L Series	★ Northern	\$57,796.00
Atlantic Truck Center	Sterling L Series	★ Central	\$57,796.00
Atlantic Truck Center	Sterling L Series	★ Southern	\$57,796.00
Nextran Truck Center - Lake City	Volvo V Series	Western	\$87,299.00
Nextran Truck Center - Lake City	Volvo V Series	Northern	\$87,049.00
Nextran Truck Center - Tampa	Volvo V Series	Central	\$87,177.00
General GMC Truck Sales & Service, Inc.	Volvo V Series	Southern	\$82,828.00
Heintzelman's Truck Center, Inc.	Western Star 4900	Western	\$79,991.00
Heintzelman's Truck Center, Inc.	Western Star 4900	Northern	\$79,991.00
Heintzelman's Truck Center, Inc.	Western Star 4900	Central	\$79,991.00
Heintzelman's Truck Center, Inc.	Western Star 4900	Southern	\$79,991.00

60,000 LB. GVWR CAB & CHASSIS - 4X6 TANDEM AXLE REFUSE TRUCK (Specification #50)

Atlantic Truck Center	American LaFrance Condor	★ Western	\$99,848.00
Atlantic Truck Center	American LaFrance Condor	★ Northern	\$99,848.00
Atlantic Truck Center	American LaFrance Condor	★ Central	\$99,848.00
Atlantic Truck Center	American LaFrance Condor	★ Southern	\$99,848.00
Kenworth of Central Florida	Autocar WX64	Western	— NB —
Kenworth of Central Florida	Autocar WX64	Northern	\$116,373.00
Kenworth of Central Florida	Autocar WX64	Central	\$115,998.00
General GMC Truck Sales & Service, Inc.	Autocar WX64	Southern	\$115,139.00
Container Systems & Equip. Co., Inc.	Crane Carrier LET2	Western	\$131,986.00
Container Systems & Equip. Co., Inc.	Crane Carrier LET2	Northern	\$131,986.00
Container Systems & Equip. Co., Inc.	Crane Carrier LET2	Central	\$131,986.00
Container Systems & Equip. Co., Inc.	Crane Carrier LET2	Southern	\$131,986.00
Nextran Truck Center - Lake City	Mack MR Series	Western	\$109,997.00
Nextran Truck Center - Lake City	Mack MR Series	Northern	\$109,747.00
Nextran Truck Center - Tampa	Mack MR Series	Central	\$109,747.00
Nextran Truck Center - Miami	Mack MR Series	Southern	\$110,237.00
Rush Truck Center - Tampa	Peterbilt 320	Western	\$105,133.00

Name of Dealership	Type of Vehicle	Zone	Base Price
60,000 LB. GVWR CAB & CHASSIS - 4X6 TANDEM AXLE REFUSE TRUCK (Specification #50)			
<i>(continued)</i>			
Rush Truck Center - Tampa	Peterbilt 320	Northern	\$105,133.00
Rush Truck Center - Tampa	Peterbilt 320	Central	\$105,133.00
Rush Truck Center - Tampa	Peterbilt 320	Southern	\$105,133.00

★ = Specification Low Bid

AWARDED DEALERS

Atlantic Truck Center

2565 W. State Road 84

Ft. Lauderdale, FL 33312

Vehicles: Ford, Sterling, & ALF Condor

Contact: George Ellison/Drew Ellison

Phone: 888-763-7626

407-862-7408

FAX: 407-862-3849

Email: geowing@aol.com

Vehicle: Freightliner

Contact: Albert Johnsen

Phone: 786-279-2015

FAX: 305-651-3618

Email: ajohnsen@atlantictrucks.com

Champion Chevrolet, Inc.

3127 W. Tennessee Street

Tallahassee, FL 32304

Contact: Don Gates

Phone: 850-580-7631

FAX: 850-575-9027

Email: dgates@championchevy.com

Classic Chevrolet Company

P.O. Box 1720

Winter Park, FL 32790

Contact: Freddy Carter

Phone: 407-298-1535 ext. 269

407-948-3543 (cell)

FAX: 407-298-6170

Email: fcarter@asnmail.com

Container Systems & Equip. Co., Inc.

P.O. Box 249

Daytona Beach, FL 32115

Contact: Bill Young

Phone: 386-253-5555

FAX: 386-253-8537

Email: bgyoung@att.net

General GMC Truck Sales & Service, Inc.

360 South Military Trail

West Palm Beach, FL 33415

Contact: Ron Miller

Phone: 561-686-8906

FAX: 561-697-8429

Email: rmiller@generalgmc.com

Heintzelmans Truck Center, Inc.

2424 John Young Parkway

Orlando, FL 32804

Contact: Bob Scharpnick

Phone: 407-298-1000 ext. 126

FAX: 407-292-3550

Email: bscharpnick@heintzelmans.com

Kenworth of Central Florida

1800 N. Orange Blossom Trail

Orlando, FL 32804

Contact: Richard "Smitty" Smith

Phone: 800-871-2244 ext. 106

FAX: 407-648-2786

Email: rsmith@kenworthcentfl.com

Maroone Chevrolet, LLC

P.O. Box 848480

Pembroke Pines, FL 33084-0480

Contact: David Fridgant

Phone: 954-447-2150

FAX: 954-433-8503

Email: fridgantd@autonation.com

Maudlin International Trucks

4900 N. Orange Blossom Trail

Orlando, FL 32810

Contact: Jeff Rotella

Phone: 407-466-6951

FAX: 407-292-8542

Email: jarotella@maudlinintl.com

AWARDED DEALERS (Continued)

Nextran Truck Center – Lake City

328 S.W. Ring Court

Lake City, FL 32025

Contact: Barry Sessions

Phone: 386-754-8822

800-559-6225

FAX: 386-754-8833

Email: bsessions@nextrancorp.com

Nextran Truck Center – Miami

6801 N.W. 74th Avenue

Miami, FL 33166

Contact: N. J. "Nic" Nichols

Phone: 305-883-8506 ext. 407

FAX: 305-883-9808

Email: nnichols@nextrancorp.com

Nextran Truck Center – Tampa

7810 Adamo Drive

Tampa, FL 33619

Contact: John A. Louer

Phone: 813-626-7141

800-932-6225

FAX: 813-627-8831

Email: jlouer@nextrancorp.com

Orville Beckford Ford-Mercury

6400 Hwy. 90

Milton, FL 32570

Contact: Joseph L. Windrow

Phone: 800-525-2234 ext. 259

850-623-2234 ext. 259

FAX: 850-626-9591

Email: windrow1@bellsouth.net

Rechtien International Trucks, Inc.

3787 Interstate Park Road

Riviera Beach, FL 33404

Contact: John Bradley

Phone: 561-882-9050

FAX: 561-882-0218

Email: bradley@rechtien.com

Rush Truck Center – Tampa

8411 Sabal Industrial Blvd.

Tampa, FL 33619

Contact: Paul Rosencrans

Phone: 813-664-1441

FAX: 813-626-5024

Email: rosencransp@rush-enterprises.com

Sun State International Trucks, LLC

6020 Adamo Drive

Tampa, FL 33619

Contact: Alan Beyer

Phone: 813-621-1331 ext. 1010

FAX: 813-628-0527

Email: alanb@mail.sunstintl.com

As an added feature to the Cooperative Bid Program, the **Florida Sheriffs Association** offers several financing programs. Please note that these financing programs are not part of the bid process, and therefore, do not constitute a formal bid award. Although these financing programs are recommended by the Florida Sheriffs Association, participating agencies have the ability to seek their own financing or leasing arrangement with other leasing/financing companies of their choice.

The **Florida Sheriffs Association Tax Exempt Installment Financing Program** is available to Sheriffs, Units of Local Governments, Municipalities and Police Agencies to finance vehicles and a variety of other types of equipment and projects. The program allows low tax exempt financing of equipment over its useful life which allows you to update your fleet, maintain proper fleet rotation, and control and lower maintenance costs. The program is offered in conjunction with **Mears Motor Leasing**. Any questions or requests for quotes should be directed to **Mears Motor Leasing**, at (407) 253-4464. Please see page 222 for additional information on the lease/purchase program.

The **Florida Sheriffs Association Police Car Lease Program** is also available to finance vehicles. This plan is not a straight lease nor a straight finance program. It is the best of both. This plan takes advantage of the special low municipal finance rate (previously only available on a finance plan) and at the same time allows agencies to pay only for the useful life of the car. This program is also offered in conjunction with **Mears Motor Leasing**. Any questions or request for quotes should be directed to **Mears Motor Leasing** at (407) 253-4464. Please see page 1425 for additional information on this program.

The Florida Sheriffs Association also offers an “**Operating Lease Program**” for police vehicles and equipment through **Ontario Fleet Leasing**. This unique program is currently financed at our low interest rate of 4.9%. Program highlights are as follows:

- Lease patrol, sport utility, motorcycles, emergency, crime scene and unmarked vehicles;
- Unlimited mileage option is available;
- Eliminates the formal bidding process;
- The lease is recognized as an operating lease in accordance with FASB 13 standards;
- The County has the option to run the vehicles through their annual auction;
- The Sheriff's Office will share in the auction's proceeds.

Any questions or request for quotes should be directed to **Ontario Fleet Leasing** at (315) 431-4676.

We would like to thank you in advance for your time and interest in this program and ask that you feel free to contact **Peggy Goff** with the **Florida Sheriffs Association** at (850) 877-2165 should you have any questions regarding these financing or leasing programs.

BASIC INFORMATION REQUIRED ON A VEHICLE PURCHASE ORDER

When filling out a purchase order for a vehicle that is to be purchased under the Florida Sheriffs Association, Florida Association of Counties and Florida Fire Chiefs' Association Bid No. 06-14-0821A, there are certain items of information that must be on the purchase order, or enclosed with the purchase order, so as to minimize the possibility of errors on the order.

This information includes, but is not limited to, the following:

- Date of order
- Purchase order number
- Originator of purchase order
- Name and number (phone & fax) of contact person responsible for receiving "Confirmation of Order" and scheduling of delivery.
- Delivery date required
- Contract number (06-14-0821A)
- Contract specification number of vehicle(s), number of vehicles ordered and base price of vehicles
- Type vehicle ordered (i.e. Ford F-750 or International 4300V SBA)
- FIN CODE for the Florida Sheriffs Association (QE065) and your agency's FIN CODE when ordering FORD products
- FAN CODE for the Florida Sheriffs Association (917872) and your agency's FAN CODE when ordering GENERAL MOTORS products
- FAN CODE for the Florida Sheriffs Association (49313) and your agency's FAN CODE when ordering CHRYSLER products
- Individual listing of each option ordered under the contract, along with each option cost
- Individual listing of each non-contract option ordered, along with each option cost
- Total cost of vehicle(s)
- Line item for administrative fee for trucks starting at 52,000 lb. GVWR and all heavy equipment
- Copy of dealer's quote for non-contract option(s)
- Copy of vehicle(s) specifications (if different from contract specifications)

Inclusion of the above mentioned items will help prevent possible misunderstanding of the order and will assist in any audit of the purchase orders, or vehicles, that may be deemed necessary in the future.

DISTRICT MAP

WESTERN

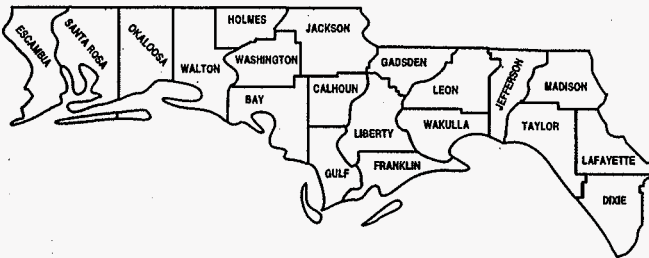

WESTERN
 ESCAMBIA
 SANTA ROSA
 OKALOOSA
 WALTON
 HOLMES
 WASHINGTON
 BAY
 JACKSON
 CALHOUN
 GULF
 LIBERTY
 FRANKLIN
 GADSDEN
 WAKULLA
 LEON
 JEFFERSON
 TAYLOR
 MADISON
 LAFAYETTE
 DIXIE

NORTHERN
 GILCHRIST
 ALACHUA
 UNION
 BRADFORD
 BAKER
 NASSAU
 DUVAL
 CLAY
 PUTNAM
 ST. JOHNS
 FLAGLER
 VOLUSIA
 MARION
 LEVY
 HAMILTON
 COLUMBIA
 SUWANNEE

NORTHERN

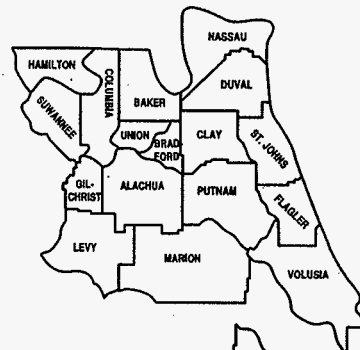

CENTRAL

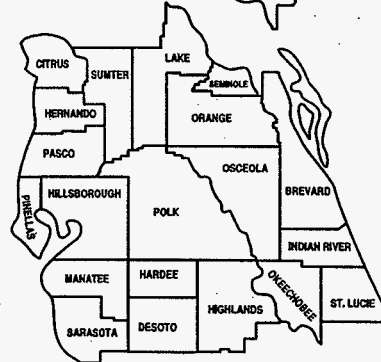

CENTRAL
 CITRUS
 SUMTER
 LAKE
 HERNANDO
 SEMINOLE
 ORANGE
 PASCO
 PINELLAS
 HILLSBOROUGH
 POLK
 OSCEOLA
 BREVARD
 INDIAN RIVER
 MANATEE
 HARDEE
 HIGHLANDS
 OKEECHOBEE
 ST. LUCIE
 SARASOTA
 DESOTO

SOUTHERN
 CHARLOTTE
 LEE
 GLADES
 MARTIN
 HENDRY
 PALM BEACH
 COLLIER
 BROWARD
 MONROE
 MIAMI-DADE

SOUTHERN

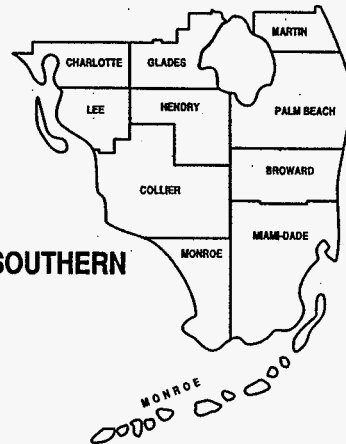

**BID AWARD
ANNOUNCEMENT**

06-14-0821A

**PURSUIT,
ADMINISTRATIVE NON-PURSUIT,
UTILITY VEHICLES, TRUCKS & VANS,
& OTHER FLEET EQUIPMENT**

*Participating Sheriff's Offices & Local Governmental
Agencies of the State of Florida*

Coordinated By

The

**Florida Sheriffs Association,
Florida Association of Counties &
Florida Fire Chiefs' Association**



TABLE OF CONTENTS

ORDERING INSTRUCTIONS	6
Overview of Awarded Specifications	7
Awarded Dealers	13
Basic Information REQUIRED for Purchase Orders	16
District Map	17

SPECIFICATIONS 1-45 AND 51-60 WERE AWARDED ON BID 06-14-0821

- Specification #1 – Full Size Vehicles - RWD (Police Package)
- Specification #2 – Full Size Vehicles - FWD (Police Package)
- Specification #3 – Full Size Utility Vehicles - RWD (Police Package)
- Specification #4 – Full Size 4-Door Administrative Vehicles
- Specification #5 – Mid Size 4-Door Administrative Vehicles
- Specification #6 – Compact 4-Door Administrative Vehicles
- Specification #7 – Hybrid 4-Door Administrative Vehicles
- Specification #8 – Small 4 Passenger Electric Vehicle
- Specification #9 – Off-Road Utility Vehicle
- Specification #10 – Police Motorcycle
- Specification #11 – Motorcycle
- Specification #12 – Hybrid Small Size 4-Door Utility Vehicles - FWD
- Specification #13 – Hybrid Small Size 4-Door Utility Vehicles - 4x4
- Specification #14 – Small Size 4-Door Utility Vehicles - 4x2
- Specification #15 – Small Size 4-Door Utility Vehicles - 4x4 or AWD
- Specification #16 – Mid Size 4-Door Utility Vehicles - 4x2
- Specification #17 – Mid Size 4-Door Utility Vehicles - 4x4
- Specification #18 – Full Size 4-Door Utility Vehicles - 4x2
- Specification #19 – Full Size 4-Door Utility Vehicles - 4x4
- Specification #20 – 1/2 Ton 4-Door Extended Wheelbase Utility Vehicles - 4x2
- Specification #21 – 1/2 Ton 4-Door Extended Wheelbase Utility Vehicles - 4x4
- Specification #22 – 3/4 Ton 4-Door Extended Wheelbase Utility Vehicles - 4x2
- Specification #23 – 3/4 Ton 4-Door Extended Wheelbase Utility Vehicles - 4x4
- Specification #24 – 7 Passenger Mini Van - FWD
- Specification #25 – 8 Passenger Van - RWD
- Specification #26 – 12 Passenger Van
- Specification #27 – 15 Passenger Van
- Specification #28 – Utility Cargo Van
- Specification #29 – Compact Pickup Truck - 4x2
- Specification #30 – Compact Pickup Truck - 4x4
- Specification #31 & #32 – Hybrid 1/2 Ton Extended Cab Pickup Truck
- Specification #33 – 1/2 Ton Pickup Truck - 4x2
- Specification #34 – 1/2 Ton Pickup Truck - 4x4
- Specification #35 – 3/4 Ton Pickup Truck - 4x2
- Specification #36 – 3/4 Ton Pickup Truck - 4x4

- Specification #37 – 1 Ton Pickup Truck (Dual Rear Wheel) - 4x2
- Specification #38 – 1 Ton Pickup Truck (Dual Rear Wheel) - 4x4
- Specification #39 – 1 Ton Cab & Chassis (Dual Rear Wheel) - 4x2
- Specification #40 – 1 Ton Cab & Chassis (Dual Rear Wheel) - 4x4
- Specification #41 – 12,000 lb. GVWR Minimum Tilt Cab & Chassis
- Specification #42 – 15,000 lb. GVWR Cab & Chassis (Dual Rear Wheel) - 4x2
- Specification #43 – 15,000 lb. GVWR Cab & Chassis (Dual Rear Wheel) - 4x4
- Specification #44 – 17,501 lb. GVWR Cab & Chassis (Dual Rear Wheel) - 4x2
- Specification #45 – 17,501 lb. GVWR Cab & Chassis (Dual Rear Wheel) - 4x4

Specification #46 – 25,500 lb. GVWR Cab & Chassis (Dual Rear Wheel) - 4x2	
Awarded Dealer(s).....	18
Base Specifications.....	20
Ford F-650	22
Chevrolet Kodiak 7500	29
GMC TC7500	35
Freightliner M2	40
Hino 268A.....	45
International 4300V SBA	51
Kenworth T300	57
Peterbilt 330.....	63
Sterling Acterra.....	69
Specification #47 – 30,000 lb. GVWR Cab & Chassis (Dual Rear Wheel) - 4x2	
Awarded Dealer(s).....	74
Base Specifications.....	76
Ford F-750	78
Chevrolet CC7500	85
GMC TC7500	92
Freightliner M2	98
Hino 338	105
International 4300V SBA	111
Kenworth T300	117
Peterbilt 335	123
Sterling Acterra.....	129
Specification #48 – 52,000 lb. GVWR Cab & Chassis 4x6 Tandem Axle Truck Tractor	
Awarded Dealer(s).....	135
Base Specifications.....	137
Autocar WX64.....	139
Freightliner M2-112.....	142
International 7600	145
Kenworth T800	148
Mack C or G Series	151
Peterbilt 367	154
Sterling LT9500	157
Volvo V Series	160
Western Star 4900	163
Specification #49 – 52,000 lb. GVWR Cab & Chassis 4x6 Tandem Axle Truck	
Awarded Dealer(s).....	166
Base Specifications.....	168
Autocar WX64.....	170

Specification #49 – 52,000 lb. GVWR Cab & Chassis 4x6 Tandem Axle Truck <i>(continued)</i>	
Freightliner M2-112	173
International 7600	176
Kenworth T800	179
Mack C or G Series	183
Peterbilt 367	187
Sterling L Series	190
Volvo V Series	193
Western Star 4900	197

Specification #50 – 60,000 lb. GVWR Cab & Chassis 4x6 Tandem Axle Refuse Truck	
Awarded Dealer(s)	200
Base Specifications	201
American LaFrance Condor	203
Autocar WX64	206
Crane Carrier LET2	210
Mack MR Series	213
Peterbilt 320	217

Specification #51 – 4x4 Loader Backhoe with Canopy (Standard Stick)	
Specification #52 – 3.0 Cu. Yd. Wheel Loader (Z-Bar Linkage Bucket - Parallel Arm Option)	
Specification #53 – Motorgrader	
Specification #54 – Agriculture Type Tractor (2 Wheel Drive)	
Specification #55 – Agriculture Type Tractor with Optional Boom Mower (2 Wheel Drive)	
Specification #56 – 70 HP Track Type Canopy Tractor (Standard Track - Wide Track Optional)	
Specification #57 – 90 HP Track Type Canopy Tractor (Standard Track - Wide Track Optional)	
Specification #58 – Skid Steer Loader - 1850 lb. Operating Capacity	
Specification #59 – 15 ft. Flex Wind Rotary Mower - PTO Driven	
Specification #60 – Regenerative Air Street Sweeper	

Manufacturer’s Extended Vehicle Warranty	220
Mears Motor Leasing	222

MEMO



FLORIDA SHERIFFS ASSOCIATION

P. O. Box 12519 • Tallahassee, FL 32317-2519
PHONE (850) 877-2165 • FAX (850) 878-8665
WEB SITE: <http://www.flsheriffs.org>

DATE: January 1, 2007

TO: **ALL PROSPECTIVE PARTICIPANTS**

FROM: Gary E. Perkins Lynn Meek Peggy Goff
Executive Director Vehicle Bid Coordinator Vehicle Contract Manager

RE: **SHERIFFS' OFFICES & LOCAL GOVERNMENTAL AGENCIES
OF THE STATE OF FLORIDA COOPERATIVE BID FOR
PURSUIT, ADMINISTRATIVE NON-PURSUIT, UTILITY VEHICLES,
TRUCK & VANS, & OTHER FLEET EQUIPMENT
Bid No. 06-14-0821A**

We are pleased to announce that the Florida Sheriffs Association, Florida Association of Counties and Florida Fire Chiefs' Association has successfully conducted its statewide competitive bid for the trucks which were not awarded in Bid 06-14-0821. This contract is effective beginning January 1, 2007 through September 30, 2007, as long as vehicles are available through fleet.

Bids will be extended and guaranteed to any and all units of local governments and political subdivisions including, but not limited to, county, local county board of public instruction, municipalities and/or police agencies, other local public or public safety agencies or authorities within the State of Florida. Also, in accordance with the provisions of Chapter 287, F.S., and 60A, Florida Administrative Code, any state agency including the Division of Universities, Department of Children and Family Services, Department of Health, Department of Juvenile Justice and Department of Corrections which elects and is authorized to purchase from a source other than the State of Florida contract is eligible to purchase from this bid.

In addition to the eligible users referenced above and with the consent of the successful bidder(s), purchases may be made under the terms and conditions of this contract by governmental entities located outside the State of Florida. Appropriate governmental entities' purchasing laws, rules and regulations shall apply to purchases made under this contract.

This program is designed to provide participating agencies with the most economically priced trucks, and other fleet equipment tailored to their specific needs, in a prompt and timely manner. One of the unique characteristics of this program that distinguishes it from others is that this bid contract is awarded to the lowest responsible bidder *by manufacturer* by specification by zone for all vehicles, trucks, vans and other fleet equipment.

The Florida Sheriffs Association, Florida Association of Counties and Florida Fire Chiefs' Association realize that Sheriffs' Offices, Police Agencies and other units of local governments must provide economically based maintenance and stocked parts for their fleets. They must consider overall operational cost of their vehicles instead of just considering "low bid" on the purchase of the vehicle. This program's bid award system not only provides the purchaser with the means to make sound decisions on dedicated fleet needs, but also offers the convenience of shopping and purchasing from a single contract.

All interested parties who wish to purchase from this contract may do so by following these simple procedures:

ORDERING INSTRUCTIONS

1. Contact the awarded dealership (see pages 13-14) listed in the zone from which you wish to purchase and advise them of your interest to purchase from the **Sheriffs' Offices & Local Governmental Agencies of the State of Florida Bid No. 06-14-0821A**. They will assist you with the placement of your order and answer any questions you may have regarding the vehicles purchased through this program.

All agencies ordering any FORD, GENERAL MOTORS, or CHRYSLER product, please be advised that you must use the appropriate FIN CODE/FAN CODE for the Florida Sheriffs Association in order to obtain the manufacturer's concessions. Also, you must use your FIN CODE/FAN CODE as a secondary number. For further assistance call the Fleet Customer Information Center for your appropriate manufacturer.

Manufacturer	Type Code	FSA Code	Fleet Center Contact Numbers	
FORD	FIN CODE	QE065	1-800-34-FLEET	(1-800-343-5338)
GENERAL MOTORS	FAN CODE	917872	1-800-FLEET OP	(1-800-353-3867)
DAIMLER CHRYSLER	FAN CODE	49313	1-800-999-FLEET	(1-800-999-3533)

2. **YOU MUST send a copy of the ORIGINAL PURCHASE ORDER (including FSA's Contract No. 06-14-0821A) you submitted to the participating dealer to:**

Florida Sheriffs Association
 P. O. Box 12519
 Tallahassee, Florida 32317-2519
 ATTN: Lynn Meek, Cooperative Bid Coordinator

3. **Basic information required on all purchase orders** is listed on Page 16 of this Bid Award Announcement. Purchase orders lacking the required basic information listed may result in the delay of placement and/or confirmation of orders. **NOTE:** Purchasers are reminded that the issuance of a Purchase Order does not in itself guarantee the placement of an order. The agency is responsible for filling in the requested information on the "Confirmation of Order" and submitting it along with your purchase order to the respective dealership. Dealers are required to fill in the bottom section of the "Confirmation of Order" and send it to the purchaser within seven (7) calendar days after receipt of purchase order. Purchasers are encouraged to contact the dealer if a "Confirmation of Order" has not been received within a reasonable time frame and request its issuance.
4. Agencies which elect to purchase off this contract will incur the following Administrative Fees:
 - **Pursuit, Administrative Non-Pursuit, Utility Vehicles, Trucks & Vans (Any vehicle up to 52,000 lb. GVWR)** – Dealers have included the administrative fee of \$75.00 per unit in their bid prices and made it a part of the base unit's purchase price.
 - **Trucks starting at 52,000 lb. GVWR and all Heavy Equipment** – Dealers are to charge purchasing agencies an administrative fee of 1/2 percent (.005) of the total invoice amount (base unit plus options) to be collected and paid to the FSA by the contracting dealers/manufacturer's. Administrative fees for trucks starting at 52,000 lbs. GVWR and all heavy equipment **will not** be included or made a part of the bidders base unit purchase price. This will be a separate line item on the agency's purchase order. The dealers/manufacturers will be responsible for calculating and advising the prospective purchasing agencies of the 1/2 percent (.005) administrative fee to be charged and included in the total invoice amount

at the time of order. The purchasing agencies will include the FSA administrative fee as a part of their purchase order request. Again, this will eliminate the need for purchasing agencies to have to prepare two separate purchase orders and checks.

5. In order to ensure quality service for our user agencies, we are requesting each of you to notify the Florida Sheriffs Association regarding any problems encountered in working with the awarded dealers. Any issues, including but not limited to, receipt of confirmation of order, delivery problems and communication problems, should be reported to us by e-mail at lmeek@flsheriffs.com. This information will be considered in future bid awards in order to ensure that agencies are receiving the level of service required of dealers who wish to participate in this program.
6. Add/delete options might include a superscript listed by the Order Code. The purpose of the superscript is to identify which options correlate to a specific dealer. Superscripts will be a number between 1 and 4, and will correspond as follows:

- 1 = Western zone dealer
- 2 = Northern zone dealer
- 3 = Central zone dealer
- 4 = Southern zone dealer

If a dealer has been awarded more than one zone, they will only have one superscript number assigned, and it will be the lowest numerical number that applies to their awarded zones. For example, if a dealer is awarded the northern and southern zones, their add/delete options for both zones will be represented by a "2" superscript.

On a final note, prospective purchasers are reminded that pursuant to Florida State Statute all fees (title, application plate transfer, etc.) are included in the base price for each vehicle. Purchasing agencies which elect to do their own title work, may wish to consider seeking reimbursement from the dealership for those transfer fees already included in the base price of each vehicle.

The Florida Sheriffs Association's, Florida Association of Counties' and Florida Fire Chiefs' Association's bid award for full size (pursuit and administrative), mid size (pursuit and administrative), utility vehicles, trucks and vans, and other fleet equipment are as follows (zones indicated with a ★ = specification low bid):

Name of Dealership	Type of Vehicle	Zone	Base Price
25,500 LB. GVWR CAB & CHASSIS (DUAL REAR WHEEL) - 4X2 (Specification #46)			
Orville Beckford Ford-Mercury	Ford F-650 (F65)	Western	\$41,643.00
Atlantic Truck Center	Ford F-650 (F65)	Northern	\$39,756.00
Atlantic Truck Center	Ford F-650 (F65)	Central	\$39,756.00
Atlantic Truck Center	Ford F-650 (F65)	Southern	\$39,756.00
Classic Chevrolet Company	Chevrolet Kodiak 7500 (CC7C042)	Western	\$42,740.00
Classic Chevrolet Company	Chevrolet Kodiak 7500 (CC7C042)	Northern	\$42,850.00
Maroone Chevrolet, LLC	Chevrolet Kodiak 7500 (CC7C042)	Central	\$41,850.00
Maroone Chevrolet, LLC	Chevrolet Kodiak 7500 (CC7C042)	Southern	\$41,600.00
Nextran Truck Center - Tampa	GMC TC7500 (TC7C042)	Western	\$42,827.00
Nextran Truck Center - Tampa	GMC TC7500 (TC7C042)	Northern	\$42,627.00
Nextran Truck Center - Tampa	GMC TC7500 (TC7C042)	Central	\$42,627.00
Nextran Truck Center - Tampa	GMC TC7500 (TC7C042)	Southern	\$42,827.00

Name of Dealership	Type of Vehicle	Zone	Base Price
--------------------	-----------------	------	------------

25,500 LB. GVWR CAB & CHASSIS (DUAL REAR WHEEL) - 4X2 (Specification #46)

(continued)

Atlantic Truck Center	Freightliner M2	Western	\$39,775.00
Atlantic Truck Center	Freightliner M2	Northern	\$39,775.00
Atlantic Truck Center	Freightliner M2	Central	\$39,775.00
Atlantic Truck Center	Freightliner M2	Southern	\$39,775.00

	Hino 268A	Western	— NB —
Kenworth of Central Florida	Hino 268A	Northern	\$54,324.00
Kenworth of Central Florida	Hino 268A	Central	\$53,949.00
Kenworth of Central Florida	Hino 268A	Southern	\$54,324.00

Sun State International Trucks, LLC	International 4300V SBA (MA015)	Western	\$40,600.00
Sun State International Trucks, LLC	International 4300V SBA (MA015)	Northern	\$40,900.00
Sun State International Trucks, LLC	International 4300V SBA (MA015)	Central	\$40,600.00
Sun State International Trucks, LLC	International 4300V SBA (MA015)	Southern	\$40,900.00

	Kenworth T300	Western	— NB —
Kenworth of Central Florida	Kenworth T300	Northern	\$56,310.00
Kenworth of Central Florida	Kenworth T300	Central	\$55,935.00
Kenworth of Central Florida	Kenworth T300	Southern	\$56,310.00

Rush Truck Center - Tampa	Peterbilt 330	Western	\$51,708.00
Rush Truck Center - Tampa	Peterbilt 330	Northern	\$51,708.00
Rush Truck Center - Tampa	Peterbilt 330	Central	\$51,708.00
Rush Truck Center - Tampa	Peterbilt 330	Southern	\$51,708.00

Atlantic Truck Center	Sterling Acterra	★ Western	\$39,434.00
Atlantic Truck Center	Sterling Acterra	★ Northern	\$39,434.00
Atlantic Truck Center	Sterling Acterra	★ Central	\$39,434.00
Atlantic Truck Center	Sterling Acterra	★ Southern	\$39,434.00

30,000 LB. GVWR CAB & CHASSIS (DUAL REAR WHEEL) - 4X2 (Specification #47)

Orville Beckford Ford-Mercury	Ford F-750 (F75)	Western	\$41,543.00
Atlantic Truck Center	Ford F-750 (F75)	★ Northern	\$38,656.00
Atlantic Truck Center	Ford F-750 (F75)	★ Central	\$38,656.00
Atlantic Truck Center	Ford F-750 (F75)	★ Southern	\$38,656.00

Champion Chevrolet, Inc.	Chevrolet CC7500 (CC7C042)	Western	\$46,129.63
Champion Chevrolet, Inc.	Chevrolet CC7500 (CC7C042)	Northern	\$46,129.63
Maroone Chevrolet, LLC	Chevrolet CC7500 (CC7C042)	Central	\$42,900.00
Maroone Chevrolet, LLC	Chevrolet CC7500 (CC7C042)	Southern	\$42,650.00

Nextran Truck Center - Tampa	GMC TC7500 (TC7C042)	Western	\$43,587.00
Nextran Truck Center - Tampa	GMC TC7500 (TC7C042)	Northern	\$43,287.00
Nextran Truck Center - Tampa	GMC TC7500 (TC7C042)	Central	\$43,287.00
Nextran Truck Center - Tampa	GMC TC7500 (TC7C042)	Southern	\$43,487.00

Atlantic Truck Center	Freightliner M2	Western	\$39,514.00
Atlantic Truck Center	Freightliner M2	Northern	\$39,514.00

Name of Dealership	Type of Vehicle	Zone	Base Price
--------------------	-----------------	------	------------

30,000 LB. GVWR CAB & CHASSIS (DUAL REAR WHEEL) - 4X2 (Specification #47)
(continued)

Atlantic Truck Center	Freightliner M2	Central	\$39,514.00
Atlantic Truck Center	Freightliner M2	Southern	\$39,514.00
	Hino 338	Western	— NB —
Kenworth of Central Florida	Hino 338	Northern	\$58,720.00
Kenworth of Central Florida	Hino 338	Central	\$58,345.00
Kenworth of Central Florida	Hino 338	Southern	\$58,720.00
Sun State International Trucks, LLC	International 4300V SBA (MA015)	Western	\$41,300.00
Sun State International Trucks, LLC	International 4300V SBA (MA015)	Northern	\$41,600.00
Sun State International Trucks, LLC	International 4300V SBA (MA015)	Central	\$41,300.00
Sun State International Trucks, LLC	International 4300V SBA (MA015)	Southern	\$41,600.00
	Kenworth T300	Western	— NB —
Kenworth of Central Florida	Kenworth T300	Northern	\$60,235.00
Kenworth of Central Florida	Kenworth T300	Central	\$59,860.00
Kenworth of Central Florida	Kenworth T300	Southern	\$60,235.00
Rush Truck Center - Tampa	Peterbilt 335	Western	\$58,445.00
Rush Truck Center - Tampa	Peterbilt 335	Northern	\$58,445.00
Rush Truck Center - Tampa	Peterbilt 335	Central	\$58,445.00
Rush Truck Center - Tampa	Peterbilt 335	Southern	\$58,445.00
Atlantic Truck Center	Sterling Acterra	★ Western	\$39,120.00
Atlantic Truck Center	Sterling Acterra	Northern	\$39,120.00
Atlantic Truck Center	Sterling Acterra	Central	\$39,120.00
Atlantic Truck Center	Sterling Acterra	Southern	\$39,120.00

52,000 LB. GVWR CAB & CHASSIS - 4X6 TANDEM AXLE TRUCK TRACTOR (Specification #48)

	Autocar WX64	Western	— NB —
Kenworth of Central Florida	Autocar WX64	Northern	\$122,443.00
Kenworth of Central Florida	Autocar WX64	Central	\$122,068.00
	Autocar WX64	Southern	— NB —
Atlantic Truck Center	Freightliner M2-112	Western	\$63,071.00
Atlantic Truck Center	Freightliner M2-112	Northern	\$63,071.00
Atlantic Truck Center	Freightliner M2-112	Central	\$63,071.00
Atlantic Truck Center	Freightliner M2-112	Southern	\$63,071.00
Maudlin International Trucks	International 7600	Western	\$71,995.00
Maudlin International Trucks	International 7600	Northern	\$71,695.00
Maudlin International Trucks	International 7600	Central	\$71,495.00
Rechtien International Trucks, Inc.	International 7600	Southern	\$70,703.00
	Kenworth T800	Western	— NB —
Kenworth of Central Florida	Kenworth T800	Northern	\$81,855.00
Kenworth of Central Florida	Kenworth T800	Central	\$81,480.00
Kenworth of Central Florida	Kenworth T800	Southern	\$81,855.00

Name of Dealership	Type of Vehicle	Zone	Base Price
--------------------	-----------------	------	------------

52,000 LB. GVWR CAB & CHASSIS - 4X6 TANDEM AXLE TRUCK TRACTOR (Specification #48)
(continued)

Nextran Truck Center - Lake City	Mack C or G Series	Western	\$78,997.00
Nextran Truck Center - Lake City	Mack C or G Series	Northern	\$78,747.00
Nextran Truck Center - Tampa	Mack C or G Series	Central	\$78,747.00
Nextran Truck Center - Miami	Mack C or G Series	Southern	\$79,237.00
Rush Truck Center - Tampa	Peterbilt 367	Western	\$90,804.00
Rush Truck Center - Tampa	Peterbilt 367	Northern	\$90,804.00
Rush Truck Center - Tampa	Peterbilt 367	Central	\$90,804.00
Rush Truck Center - Tampa	Peterbilt 367	Southern	\$90,804.00
Atlantic Truck Center	Sterling LT9500	★ Western	\$62,471.00
Atlantic Truck Center	Sterling LT9500	★ Northern	\$62,471.00
Atlantic Truck Center	Sterling LT9500	★ Central	\$62,471.00
Atlantic Truck Center	Sterling LT9500	★ Southern	\$62,471.00
Nextran Truck Center - Lake City	Volvo V Series	Western	\$86,676.00
Nextran Truck Center - Lake City	Volvo V Series	Northern	\$86,426.00
Nextran Truck Center - Tampa	Volvo V Series	Central	\$86,427.00
General GMC Truck Sales & Service, Inc.	Volvo V Series	Southern	\$82,828.00
Heintzelman's Truck Center, Inc.	Western Star 4900	Western	\$81,178.00
Heintzelman's Truck Center, Inc.	Western Star 4900	Northern	\$81,178.00
Heintzelman's Truck Center, Inc.	Western Star 4900	Central	\$81,178.00
Heintzelman's Truck Center, Inc.	Western Star 4900	Southern	\$81,178.00

52,000 LB. GVWR CAB & CHASSIS - 4X6 TANDEM AXLE TRUCK (Specification #49)

Kenworth of Central Florida	Autocar WX64	Western	— NB —
Kenworth of Central Florida	Autocar WX64	Northern	\$116,332.00
Kenworth of Central Florida	Autocar WX64	Central	\$115,957.00
Kenworth of Central Florida	Autocar WX64	Southern	— NB —
Atlantic Truck Center	Freightliner M2-112	Western	\$61,367.00
Atlantic Truck Center	Freightliner M2-112	Northern	\$61,367.00
Atlantic Truck Center	Freightliner M2-112	Central	\$61,367.00
Atlantic Truck Center	Freightliner M2-112	Southern	\$61,367.00
Sun State International Trucks, LLC	International 7600	Western	\$68,300.00
Sun State International Trucks, LLC	International 7600	Northern	\$68,600.00
Sun State International Trucks, LLC	International 7600	Central	\$68,300.00
Sun State International Trucks, LLC	International 7600	Southern	\$68,600.00
Kenworth of Central Florida	Kenworth T800	Western	— NB —
Kenworth of Central Florida	Kenworth T800	Northern	\$82,234.00
Kenworth of Central Florida	Kenworth T800	Central	\$81,859.00
Kenworth of Central Florida	Kenworth T800	Southern	\$82,234.00
Nextran Truck Center - Lake City	Mack C or G Series	Western	\$85,897.00

Name of Dealership	Type of Vehicle	Zone	Base Price
--------------------	-----------------	------	------------

52,000 LB. GVWR CAB & CHASSIS - 4X6 TANDEM AXLE TRUCK (Specification #49)

(continued)

Nextran Truck Center - Lake City	Mack C or G Series	Northern	\$85,647.00
Nextran Truck Center - Tampa	Mack C or G Series	Central	\$85,647.00
Nextran Truck Center - Miami	Mack C or G Series	Southern	\$86,137.00
Rush Truck Center - Tampa	Peterbilt 367	Western	\$89,986.00
Rush Truck Center - Tampa	Peterbilt 367	Northern	\$89,986.00
Rush Truck Center - Tampa	Peterbilt 367	Central	\$89,986.00
Rush Truck Center - Tampa	Peterbilt 367	Southern	\$89,986.00
Atlantic Truck Center	Sterling L Series	★ Western	\$57,796.00
Atlantic Truck Center	Sterling L Series	★ Northern	\$57,796.00
Atlantic Truck Center	Sterling L Series	★ Central	\$57,796.00
Atlantic Truck Center	Sterling L Series	★ Southern	\$57,796.00
Nextran Truck Center - Lake City	Volvo V Series	Western	\$87,299.00
Nextran Truck Center - Lake City	Volvo V Series	Northern	\$87,049.00
Nextran Truck Center - Tampa	Volvo V Series	Central	\$87,177.00
General GMC Truck Sales & Service, Inc.	Volvo V Series	Southern	\$82,828.00
Heintzelman's Truck Center, Inc.	Western Star 4900	Western	\$79,991.00
Heintzelman's Truck Center, Inc.	Western Star 4900	Northern	\$79,991.00
Heintzelman's Truck Center, Inc.	Western Star 4900	Central	\$79,991.00
Heintzelman's Truck Center, Inc.	Western Star 4900	Southern	\$79,991.00

60,000 LB. GVWR CAB & CHASSIS - 4X6 TANDEM AXLE REFUSE TRUCK (Specification #50)

Atlantic Truck Center	American LaFrance Condor	★ Western	\$99,848.00
Atlantic Truck Center	American LaFrance Condor	★ Northern	\$99,848.00
Atlantic Truck Center	American LaFrance Condor	★ Central	\$99,848.00
Atlantic Truck Center	American LaFrance Condor	★ Southern	\$99,848.00
Kenworth of Central Florida	Autocar WX64	Western	— NB —
Kenworth of Central Florida	Autocar WX64	Northern	\$116,373.00
Kenworth of Central Florida	Autocar WX64	Central	\$115,998.00
General GMC Truck Sales & Service, Inc.	Autocar WX64	Southern	\$115,139.00
Container Systems & Equip. Co., Inc.	Crane Carrier LET2	Western	\$131,986.00
Container Systems & Equip. Co., Inc.	Crane Carrier LET2	Northern	\$131,986.00
Container Systems & Equip. Co., Inc.	Crane Carrier LET2	Central	\$131,986.00
Container Systems & Equip. Co., Inc.	Crane Carrier LET2	Southern	\$131,986.00
Nextran Truck Center - Lake City	Mack MR Series	Western	\$109,997.00
Nextran Truck Center - Lake City	Mack MR Series	Northern	\$109,747.00
Nextran Truck Center - Tampa	Mack MR Series	Central	\$109,747.00
Nextran Truck Center - Miami	Mack MR Series	Southern	\$110,237.00
Rush Truck Center - Tampa	Peterbilt 320	Western	\$105,133.00

Name of Dealership	Type of Vehicle	Zone	Base Price
--------------------	-----------------	------	------------

60,000 LB. GVWR CAB & CHASSIS - 4X6 TANDEM AXLE REFUSE TRUCK (Specification #50)
(continued)

Rush Truck Center - Tampa	Peterbilt 320	Northern	\$105,133.00
Rush Truck Center - Tampa	Peterbilt 320	Central	\$105,133.00
Rush Truck Center - Tampa	Peterbilt 320	Southern	\$105,133.00

★ = Specification Low Bid

AWARDED DEALERS

Atlantic Truck Center
2565 W. State Road 84
Ft. Lauderdale, FL 33312
Vehicles: Ford, Sterling, & ALF Condor
Contact: George Ellison/Drew Ellison
Phone: 888-763-7626
407-862-7408
FAX: 407-862-3849
Email: geowing@aol.com
Vehicle: Freightliner
Contact: Albert Johnsen
Phone: 786-279-2015
FAX: 305-651-3618
Email: ajohnsen@atlantictrucks.com

Champion Chevrolet, Inc.
3127 W. Tennessee Street
Tallahassee, FL 32304
Contact: Don Gates
Phone: 850-580-7631
FAX: 850-575-9027
Email: dgates@championchevy.com

Classic Chevrolet Company
P.O. Box 1720
Winter Park, FL 32790
Contact: Freddy Carter
Phone: 407-298-1535 ext. 269
407-948-3543 (cell)
FAX: 407-298-6170
Email: fcarter@asnmil.com

Container Systems & Equip. Co., Inc.
P.O. Box 249
Daytona Beach, FL 32115
Contact: Bill Young
Phone: 386-253-5555
FAX: 386-253-8537
Email: bgyoung@att.net

General GMC Truck Sales & Service, Inc.
360 South Military Trail
West Palm Beach, FL 33415
Contact: Ron Miller
Phone: 561-686-8906
FAX: 561-697-8429
Email: rmiller@generalgmc.com

Heintzelmans Truck Center, Inc.
2424 John Young Parkway
Orlando, FL 32804
Contact: Bob Scharpnick
Phone: 407-298-1000 ext. 126
FAX: 407-292-3550
Email: bscharpnick@heintzelmans.com

Kenworth of Central Florida
1800 N. Orange Blossom Trail
Orlando, FL 32804
Contact: Richard "Smitty" Smith
Phone: 800-871-2244 ext. 106
FAX: 407-648-2786
Email: rsmith@kenworthcentfl.com

Maroone Chevrolet, LLC
P.O. Box 848480
Pembroke Pines, FL 33084-0480
Contact: David Fridgant
Phone: 954-447-2150
FAX: 954-433-8503
Email: fridgantd@autonation.com

Maudlin International Trucks
4900 N. Orange Blossom Trail
Orlando, FL 32810
Contact: Jeff Rotella
Phone: 407-466-6951
FAX: 407-292-8542
Email: jarotella@maudlinintl.com

AWARDED DEALERS (Continued)

Nextran Truck Center – Lake City

328 S.W. Ring Court

Lake City, FL 32025

Contact: Barry Sessions

Phone: 386-754-8822

800-559-6225

FAX: 386-754-8833

Email: bsessions@nextrancorp.com

Nextran Truck Center – Miami

6801 N.W. 74th Avenue

Miami, FL 33166

Contact: N. J. "Nic" Nichols

Phone: 305-883-8506 ext. 407

FAX: 305-883-9808

Email: nnichols@nextrancorp.com

Nextran Truck Center – Tampa

7810 Adamo Drive

Tampa, FL 33619

Contact: John A. Louer

Phone: 813-626-7141

800-932-6225

FAX: 813-627-8831

Email: jlouer@nextrancorp.com

Orville Beckford Ford-Mercury

6400 Hwy. 90

Milton, FL 32570

Contact: Joseph L. Windrow

Phone: 800-525-2234 ext. 259

850-623-2234 ext. 259

FAX: 850-626-9591

Email: windrow1@bellsouth.net

Rechtien International Trucks, Inc.

3787 Interstate Park Road

Riviera Beach, FL 33404

Contact: John Bradley

Phone: 561-882-9050

FAX: 561-882-0218

Email: bradley@rechtien.com

Rush Truck Center – Tampa

8411 Sabal Industrial Blvd.

Tampa, FL 33619

Contact: Paul Rosencrans

Phone: 813-664-1441

FAX: 813-626-5024

Email: rosencransp@rush-enterprises.com

Sun State International Trucks, LLC

6020 Adamo Drive

Tampa, FL 33619

Contact: Alan Beyer

Phone: 813-621-1331 ext. 1010

FAX: 813-628-0527

Email: alanb@mail.sunstintl.com

As an added feature to the Cooperative Bid Program, the **Florida Sheriffs Association** offers several financing programs. Please note that these financing programs are not part of the bid process, and therefore, do not constitute a formal bid award. Although these financing programs are recommended by the Florida Sheriffs Association, participating agencies have the ability to seek their own financing or leasing arrangement with other leasing/financing companies of their choice.

The **Florida Sheriffs Association Tax Exempt Installment Financing Program** is available to Sheriffs, Units of Local Governments, Municipalities and Police Agencies to finance vehicles and a variety of other types of equipment and projects. The program allows low tax exempt financing of equipment over its useful life which allows you to update your fleet, maintain proper fleet rotation, and control and lower maintenance costs. The program is offered in conjunction with **Mears Motor Leasing**. Any questions or requests for quotes should be directed to **Mears Motor Leasing**, at (407) 253-4464. Please see page 222 for additional information on the lease/purchase program.

The **Florida Sheriffs Association Police Car Lease Program** is also available to finance vehicles. This plan is not a straight lease nor a straight finance program. It is the best of both. This plan takes advantage of the special low municipal finance rate (previously only available on a finance plan) and at the same time allows agencies to pay only for the useful life of the car. This program is also offered in conjunction with **Mears Motor Leasing**. Any questions or request for quotes should be directed to **Mears Motor Leasing** at (407) 253-4464. Please see page 1425 for additional information on this program.

The Florida Sheriffs Association also offers an “**Operating Lease Program**” for police vehicles and equipment through **Ontario Fleet Leasing**. This unique program is currently financed at our low interest rate of 4.9%. Program highlights are as follows:

- Lease patrol, sport utility, motorcycles, emergency, crime scene and unmarked vehicles;
- Unlimited mileage option is available;
- Eliminates the formal bidding process;
- The lease is recognized as an operating lease in accordance with FASB 13 standards;
- The County has the option to run the vehicles through their annual auction;
- The Sheriff's Office will share in the auction's proceeds.

Any questions or request for quotes should be directed to **Ontario Fleet Leasing** at (315) 431-4676.

We would like to thank you in advance for your time and interest in this program and ask that you feel free to contact **Peggy Goff** with the **Florida Sheriffs Association** at (850) 877-2165 should you have any questions regarding these financing or leasing programs.

BASIC INFORMATION REQUIRED ON A VEHICLE PURCHASE ORDER

When filling out a purchase order for a vehicle that is to be purchased under the Florida Sheriffs Association, Florida Association of Counties and Florida Fire Chiefs' Association Bid No. 06-14-0821A, there are certain items of information that must be on the purchase order, or enclosed with the purchase order, so as to minimize the possibility of errors on the order.

This information includes, but is not limited to, the following:

- Date of order
- Purchase order number
- Originator of purchase order
- Name and number (phone & fax) of contact person responsible for receiving "Confirmation of Order" and scheduling of delivery.
- Delivery date required
- Contract number (06-14-0821A)
- Contract specification number of vehicle(s), number of vehicles ordered and base price of vehicles
- Type vehicle ordered (i.e. Ford F-750 or International 4300V SBA)
- FIN CODE for the Florida Sheriffs Association (QE065) and your agency's FIN CODE when ordering FORD products
- FAN CODE for the Florida Sheriffs Association (917872) and your agency's FAN CODE when ordering GENERAL MOTORS products
- FAN CODE for the Florida Sheriffs Association (49313) and your agency's FAN CODE when ordering CHRYSLER products
- Individual listing of each option ordered under the contract, along with each option cost
- Individual listing of each non-contract option ordered, along with each option cost
- Total cost of vehicle(s)
- Line item for administrative fee for trucks starting at 52,000 lb. GVWR and all heavy equipment
- Copy of dealer's quote for non-contract option(s)
- Copy of vehicle(s) specifications (if different from contract specifications)

Inclusion of the above mentioned items will help prevent possible misunderstanding of the order and will assist in any audit of the purchase orders, or vehicles, that may be deemed necessary in the future.

DISTRICT MAP

WESTERN

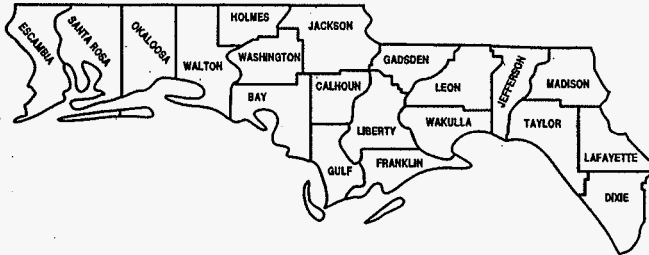

WESTERN

ESCAMBIA
SANTA ROSA
OKALOOSA
WALTON
HOLMES
WASHINGTON
BAY
JACKSON
CALHOUN
GULF
LIBERTY
FRANKLIN
GADSDEN
WAKULLA
LEON
JEFFERSON
TAYLOR
MADISON
LAFAYETTE
DIXIE

NORTHERN

GILCHRIST
ALACHUA
UNION
BRADFORD
BAKER
NASSAU
DUVAL
CLAY
PUTNAM
ST. JOHNS
FLAGLER
VOLUSIA
MARION
LEVY
HAMILTON
COLUMBIA
SUWANNEE

NORTHERN

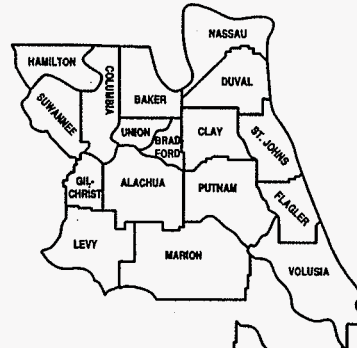

CENTRAL

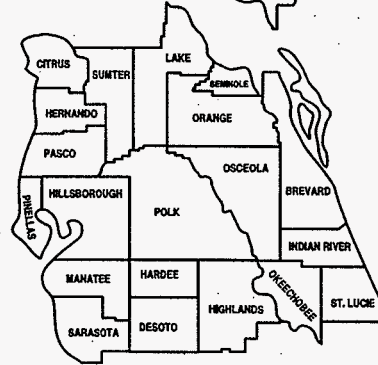

CENTRAL

CITRUS
SUMTER
LAKE
HERNANDO
SEMINOLE
ORANGE
PASCO
PINELLAS
HILLSBOROUGH
POLK
OSCEOLA
BREVARD
INDIAN RIVER
MANATEE
HARDEE
HIGHLANDS
OKEECHOBEE
ST. LUCIE
SARASOTA
DESOTO

SOUTHERN

CHARLOTTE
LEE
GLADES
MARTIN
HENDRY
PALM BEACH
COLLIER
BROWARD
MONROE
MIAMI-DADE

SOUTHERN

