



# Lee County DOT Traffic Section Design Standard for Sign Installation



Revised 9/2018

## Table of Contents

<b>Section</b>	<b>Title</b>
1.	Sign Panel Material
2.	Sign Shape
3.	Posts
4.	Fasteners
5.	Retro reflectivity and Illumination
6.	Word Messages
7.	Symbols
8.	Sign Borders
9.	Mounting Height
10.	Lateral Offset
11.	Bracing for Multi-Post Sign Panels

# Lee County DOT Traffic Design Standard for Sign Installation

## 1. Sign Panel Material

- 1.1. All sign panels installed on Lee County roadways to be of Grade 5052 H38 Aluminum material with a thickness of .080 inches (2.0 mm) or greater.

## 2. Sign Shape

- 2.1. All signs shall have the shape and size as specified in the latest version of the *Manual on Uniform Traffic Control Devices*.
- 2.2. Any border or frame around a sign shall maintain the same shape as the sign.

## 3. Posts

- 3.1. Sign posts, foundations, and mountings shall be so constructed as to hold signs in a proper and permanent position, and to resist swaying in the wind or displacement by vandalism.
- 3.2. Sign post shall be a minimum of 14 gauge steel, 2" square with a galvanized coating.
- 3.3. Extension sleeves, if used shall be a minimum of 12 gauge steel, 2.25" square with a galvanized coating.
- 3.4. The sign post or sleeve shall be installed a minimum of 30" below the finished grade.
- 3.5. Sleeves, if used, may not protrude more than 3" above the finished grade.
- 3.6. Sleeves and sign post should be pounded firmly, either manually or mechanically into the ground.
  - 3.6.1. If holes are hand dug, an 8" x 3/8" diameter galvanized steel spike or approved other mechanism shall be placed through or around the post securely approximately 1' up from bottom of hole to provide uplift resistance.
  - 3.6.2. Holes dug for all post or sleeves shall be compacted in 6 inch lifts.



Typical Sleeve with Post construction

## 4. Fasteners

- 4.1. Bolts, washers, and nuts shall be 5/16 inch stainless steel, grade 5 or greater.
- 4.2. Lock nuts with nylon insert shall be used on all installations.
- 4.3. Stainless steel washer washers .080 inch (2.0 mm) or greater thickness to be installed on face of sign at each fastening point. Washers shall have nominal SAE dimensions.
- 4.4. Fastener points are to be 3" from top and bottom of sign panel with no distance greater than 30 inches unfastened to sign post whether single or multi-post installation.
- 4.5. All fastening hardware shall be securely fastened without resulting in damage to sign sheeting

## 5. **Retro reflectivity and Illumination**

- 5.1. Regulatory, warning, and guide signs shall be retro reflective to show the same shape and similar color by both day and night. Sign sheeting with an ASTM D4956-01 Type IV (equivalent to 3M Hi-Intensity or Avery Dennison Prismatic) or better retro reflectivity shall be used.  
A sign's retro reflectivity shall meet or exceed standards set forth in the latest version of the *Manual on Uniform Traffic Control Devices*.  
Parking, standing, and stopping signs R7 and R8 series, Walking, Hitchhiking, Crossing signs R9 series R10-1 through R10-4, Acknowledgement signs and certain Bikeway signs that are intended for exclusive use by bicyclist or pedestrians may use lower sheeting grades.
  - 5.1.1. Lower grade materials may be specified by the engineer for some destination signs and guide signs on low-speed, low-volume roads.
- 5.2. Sign illumination shall not be considered as a satisfactory alternative to retro reflectivity.
- 5.3. Requirements for sign illumination shall not be considered to be satisfied by street or highway lighting.
- 5.4. All overhead sign installations require Type XI prismatic sheeting or higher. Overhead Signs will no longer require external lighting unless the sign is located along a horizontal curve with radii of 880 feet or less in rural areas and radii of 2500 feet or less in urban areas.
  - For Existing Overhead Signs with External Sign Lighting - Continue to light the sign until the lighting fixture/system or sign panel requires replacement or major repairs. Then replace existing panel with new panel meeting the current MUTCD requirements and with Type XI sheeting and remove the existing lighting system (including fixtures, support brackets, conduit, hardware, etc.). However, if the sign is located along a horizontal curve with radii of 880 feet or less in rural areas and radii of 2500 feet or less in urban areas replace the mercury vapor fixtures with approved energy efficient alternatives such as induction or LED fixtures.
  - Existing Overhead Signs Without Lighting - Replace existing panel when it no longer meets reflectivity requirements with new panel using Type XI sheeting.

## 6. **Word Messages**

- 6.1. Word messages should be as brief as possible and the lettering should be large enough to provide the necessary legibility distance. A minimum specific ratio, such as 25 mm (1 in) of letter height per 12 m (40 ft) of legibility distance, should be used.
- 6.2. Abbreviations should be kept to a minimum, and should include only those that are commonly recognized and understood, such as AVE (for Avenue), BLVD (for Boulevard), N (for North), or JCT for junction. Unacceptable abbreviations are listed in the MUTCD Table 1A-3.
- 6.3. Word messages on street name signs and destinations on guide signs may be composed of a combination of lower-case letters with initial upper-case letters.

## 7. **Symbols**

- 7.1. Only symbols recognized by the latest version of the *Manual on Uniform Traffic Control Devices* may be used on signs.

## 8. **Sign Borders**

- 8.1. Unless specifically stated otherwise, each sign illustrated herein shall have a border of the same color as the legend, at or just inside the edge. The width of the border shall be as described in the *Standard Highway Signs* manual published by FHWA.
- 8.2. The corners of all sign borders shall be rounded with a three (3) inch radius, except for STOP signs.

## 9. **Mounting Height**

- 9.1. Signs installed at the side of the road in rural districts shall be at least 1.5 m (5 ft) high, measured from the bottom of the sign to the near edge of the pavement.
- 9.2. Where parking or pedestrian movements occur, the clearance to the bottom of the sign shall be at least 2.1 m (7 ft) high.
- 9.3. The bottom of a sign shall be a maximum of 8 feet high measured from the bottom of the sign to the near edge of the pavement.
- 9.4. Directional signs, route signs, warning signs, and regulatory signs on freeways and expressways shall be installed with a minimum height of 2.1 m (7 ft).
- 9.5. If a secondary sign is mounted below another sign, the major sign shall be installed at least 2.4 m (8 ft) and the secondary sign at least 1.5 m (5 ft) above the level of the pavement edge.

## 10. **Lateral Offset**

- 10.1. All supports should be located as far as practical from the edge of the shoulder. Advantage should be taken to place signs behind existing roadside barriers
  - 10.1.1. For ground-mounted signs on high -speed, high-volume roads, the minimum lateral offset should be 3.7 meters (12 ft) from the edge of the traveled way.
  - 10.1.2. On low-volume (<400 vpd), low-speed roads (30 mph or less) offset may be 1.8 meters (6 ft)
  - 10.1.3. In areas where lateral offsets are limited, a minimum lateral offset of 0.6 m (2 ft) may be used when approved by the engineer.
  - 10.1.4. A minimum offset of 0.3 m (1 ft) from the face of the curb may be used in urban areas where sidewalk width is limited or where existing poles are close to the curb.
- 10.2. For overhead sign supports, the minimum lateral offset from the edge of the shoulder (or if no shoulder exists, from the edge of the pavement) to the near edge of overhead sign supports (cantilever or sign bridges) shall be 1.8 m (6 ft).
  - 10.2.1. Overhead sign supports shall have a barrier or crash cushion to shield them if they are within the clear zone.
- 10.3. Ground-mounted sign supports shall be breakaway, yielding, or shielded with a longitudinal barrier or crash cushion if within the clear zone.

## 11. Bracing for Multi-Post Sign Panels

11.1. Sign Panels greater than 9 square feet require multi-post installations & shall have two (2) or more lateral braces fastened to the sign panel & mounting post.

Example: A 12' wide sign panel would require 4 sign support posts.

11.2. Signs with greater than 30 inches between posts or with 24 inch or greater cantilever shall have wind bracing consisting of either a 1 3/4" x 1 3/4" "Z" channel 6061 grade aluminum (Detail 1) or 1.5 x 1.5 x .05 flat "U" channel 6061 grade aluminum (Detail 2) 3 inches from top of the sign and 3 inches from bottom of the sign. If the height of the sign exceeds 36 inches, additional wind bracing shall be provided a maximum of 24 inch spacing.

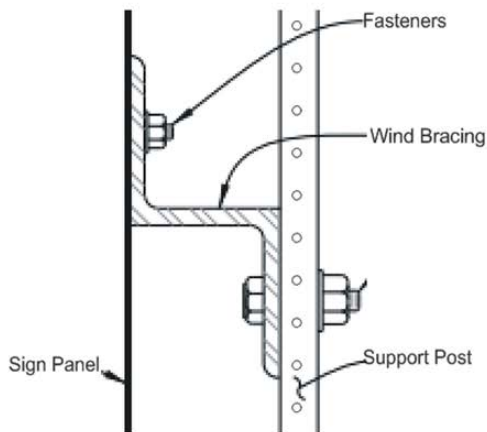

DETAIL 1

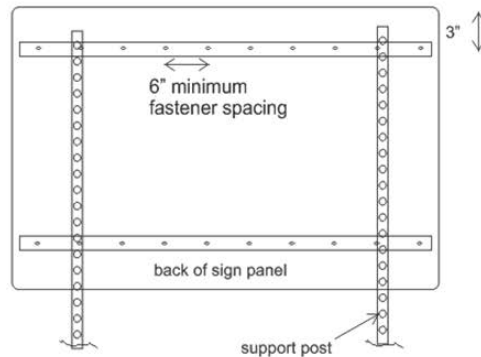

DETAIL 2