

**Lee County Board Of County Commissioners
Agenda Item Summary**

Blue Sheet No. 20041393

1. REQUESTED MOTION:

ACTION REQUESTED: Approve award of Project # EX050049, the purchase of one new Versalift Model VST-5000I aerial device and chassis for DOT from Time Manufacturing Company at the prices given in the Federal General Services Administration Contract #GS-30F-1024H. Also approve the trade-in of asset # 019726 to Time Manufacturing for an amount of \$8000. Total cost: \$111,281.

WHY ACTION IS NECESSARY: As this expenditure will exceed \$50,000, Board approval is required.

WHAT ACTION ACCOMPLISHES: Provides DOT/Traffic with a new bucket truck to replace asset # 019726 which was damaged in a fire. The cost to repair the fire damage, together with other needed repairs, will exceed the value of the truck; therefore, it will be traded in on the new vehicle.

2. DEPARTMENTAL CATEGORY:

COMMISSION DISTRICT #

C9B

3. MEETING DATE:

11-09-2004

4. AGENDA:

- CONSENT
- ADMINISTRATIVE
- APPEALS
- PUBLIC
- WALK ON
- TIME REQUIRED:

5. REQUIREMENT/PURPOSE:
(Specify)

- STATUTE
- ORDINANCE
- ADMIN. AC-4-1
- CODE
- OTHER

6. REQUESTOR OF INFORMATION:

- A. COMMISSIONER _____
- B. DEPARTMENT Transportation
- C. DIVISION _____

BY: Scott Gilbertson, P.E., Director

BACKGROUND: On October 20, 2004, the Division of Purchasing received a request from DOT and Fleet Management to purchase one new Versalift Model VST-5000I aerial device and chassis at the prices given in Federal GSA Contract #GS-30F-1024H.

Funding is available: JB5191059401.506430 - \$27,000 & PD5410417500.506430 - \$84,281

Please see attachments:

- (1) Department's Request for Purchase
- (2) Vendor's Quotation
- (3) GSA Contract #GS-30F-1024H

8. MANAGEMENT RECOMMENDATIONS:

9. RECOMMENDED APPROVAL:

A	B	C	D	E	F				G
Department Director	Purchasing or Contracts	Human Resources	Other	County Attorney	Budget Services				County Manager
<i>[Signature]</i>	<i>[Signature]</i>			<i>[Signature]</i>	<i>Cypha 10/28</i>				<i>[Signature]</i>
					OA	OM	Risk	GC	
					<i>RK 10/27</i>	<i>10/27/04</i>	<i>10/27/04</i>	<i>10/27/04</i>	

10. COMMISSION ACTION:

- _____ APPROVED
- _____ DENIED
- _____ DEFERRED
- _____ OTHER

RECEIVED BY COUNTY ADMIN: <i>[Signature]</i>
<i>10/26/04</i>
<i>4:25 pm Sur</i>
COUNTY ADMIN FORWARDED TO: <i>[Signature]</i>
<i>11/26/04</i>
<i>4PM</i>



ATTACHMENT # 1

DIVISION OF
FLEET MANAGEMENT

*OK
10/20/04
[Signature]*

To: Janet Sheehan, Purchasing Director
From: Marilyn L. Rawlings, Fleet Manager *MR*
Date: 10/18/2004
Re: Versalift Bucket Truck Model VST-5000I

Please prepare a Blue Sheet for the purchase of one Versalift Bucket Truck Model VST-5000I, for the Department of Transportation, Traffic Division.

ACTION REQUESTED:

Approve the GSA (contract #GS-30F-1024H) purchase of one (1) Versalift Bucket Truck Model VST-5000I for the Department of Transportation, Traffic Division from Time Manufacturing Co., in the amount of \$111,281.

WHY ACTION IS NECESSARY:

Board approval is required, as this expenditure will exceed \$50,000.

WHAT ACTION ACCOMPLISHES:

This purchase will provide the Department of Transportation, Traffic Division with a new reliable bucket truck to replace asset # 019726, which was damaged in a fire. The cost to repair the fire damage and other needed repairs to asset # 019726 will exceed the value of the truck, therefore we will trade asset # 019726 in on this new truck.

Funds for this purchase are available from account string #:

\$27,000 – JB5191059401.349000.9005
\$84,281 – PD54104175006430.

*String
Revised -
See
Attached
-CDF
10-21-04*

01 OCT 20 PM 2:46

H:\Acquisition Specialist\Blue Sheets\Versalift Bucket Truck for Traffic-2004.doc

Robert Franceschini - Versalift - Blue Sheet

From: Danny Brashear
To: Franceschini, Robert
Date: 10/20/2004 10:14 AM
Subject: Versalift - Blue Sheet
CC: Arnbruster, Patti

Bob,

The paper work I sent to you and Janet yesterday for this Versalift has the wrong account strings. Can you please change the account strings to the following for the blue sheet:

\$27,000 – JB5191059401.506430

\$84,281 – PD5410417500.506430.

If you have any questions, please let me know.

Thank you.

DRB.



DIVISION OF
FLEET MANAGEMENT

To: Marilyn Rawlings, Fleet Manager
From: Danny Brashear, Operations Manager *DB*
Date: 10/18/2004
Re: Bucket Truck

Marilyn,

This purchase is for Traffic to replace asset #019726. The truck was burnt up in a fire and the transmission is also bad. We can purchase the new bucket truck off of the GSA contract. We can use the funds from Risk Management and the capital funds given from the department.

Time Manufacturing is the vendor. They will give us \$8,000 as a trade in for the old truck (019726). I would rather trade the truck in since there is damage to the bucket portion of the truck. I don't think we would get any more money for it at an auction, either.

*If you have any questions, please let me know.
Thank you.
DRB.*

MATERIAL REQUEST FORM

Non-Surcharge

GSA CONTRACT # **GS-30F-1024H**

BOARD DATE: _____

Blue Sheet # _____

R.P.O. # _____

PO # _____

VENDOR: **Time Manufacturing Co**
 7601 Imperial Drive
 Waco, Texas 76702

VENDOR # _____

ORDER CONFIRMED BY: **Stan Tomchesson**

PHONE # **254-399-2100**

FAX # **254-399-2651**

DELIVERY: **150-180 days**

REPLACES ASSET # **019726**

DEPT # **T-Signals / DOT Traffic**

REGISTRATION, TITLE, AND TAGS BEING PAID FOR BY: **Lee County**

ACCOUNT STRING: **\$84,281.00 - PD54104175006430**

ACCOUNT STRING: **\$27,000.00 - JB5191059401.349000.905**

FLEET MANAGEMENT SPEC #	04-222	QTY:	UNIT PRICE
This PO is opened for DOT/Traffic to replace asset # 019726 which as been in a fire that caused damage exceeded the new purchased cost. This purchase order is based off of the GSA Contract # GS-30F-1024H.			
New, International Model-4300 4X2 cab & chassis with 33,000 lb GVWR, 84" cab to axle, five (5) speed automatic transmission, DT466 diesel engine, air conditioning and AM/FM radio. Versalift Model-VST-5000-1, insulated 50 ft. (15.2m) telescopic aerial platform lift, 55 ft (16.8m) working height with all the standard option listed in contract # GS-30F-1024H. (see attached documents)		1	\$ 99,587.00
Standard GSA Options:			
Emergency power.		1	\$ 406.00
International Allison 3500, 5-speed automatic transmission.		1	\$ 6,018.00
Set of Strobes.		2	\$ 418.00
Back up alarm.		1	\$ 197.00
Outrigger boom interlock, main & aux.		1	\$ 1,365.00
Hyd. Tool power at rear.		1	\$ 317.00
Bumper with pintle hitch & plug.		1	\$ 730.00
Bed access step and grab handles.		1	\$ 335.00
Non Contract Options:			
36" X 60" aluminum platform with door in lieu of the 24" X 48" fiberglass platform with liner and cover.		1	\$ 1,235.00
Full hydraulic jib and winch.		1	\$ 4,620.00
3,000 watt inverter.		1	\$ 3,000.00
Paint booms Omaha Orange.		1	\$ 635.00
Warranties.			
Engine has a 5-year or 150,000 mile warranty.			
Transmission has a 5-year unlimited mileage warranty.			
Medic Master box has 20-year structural warranty and an 2-year complete warranty.			
Subtotal for all options:			\$ 119,281.00
Trade in asset # 019726-1997 IHC Model 4700 with an Versalift Model-VST-5000-1 Bucket/Boom with utility boxes. Current mileage is: 90,463.			\$ 8,000.00
TOTAL AMOUNT OF PURCHASE ORDER:			\$ 111,281.00

APPROVED

BY: **Danny Brashear**

Operations Manager

DATE: **10/18/04**

**LEE COUNTY GOVERNMENT, DIVISION OF FLEET MANAGEMENT
EQUIPMENT AND VEHICLE REQUEST FORM**
(PLEASE PRINT OR TYPE)

*F- [unclear]
F-signals*

1. Department/Division: (name) PW/DOT TRAFFIC
(division) T-SIGNALS 5134

2. Requested By: (print) JOE FOOSE Phone #: 694-7600

3. Driver/Operator of this new piece of equipment: JODY MANSSELL

4. Days and hours this piece of equipment will be used: M-F 7⁰⁰A-5³⁰P

5. Location the equipment will be parked: 5650 ENTERPRISE PKWY

6. Will this be a take home vehicle? Yes No

7. Is this a replacement equipment or vehicle? Yes No

If yes: Asset #: 19726 Yr: 1997 Make: IHC Model: 4700 Meter: 90345

8. What type of equipment or vehicle are you requesting?

Select all appropriate boxes:

- | | | | | | |
|---|--|----------------------------------|---|--|--|
| <input type="checkbox"/> Sedan | <input type="checkbox"/> Pickup truck | <input type="checkbox"/> 1/4 Ton | <input type="checkbox"/> Van | <input type="checkbox"/> Excavator | <input type="checkbox"/> Gasoline |
| <input type="checkbox"/> Station Wagon | <input type="checkbox"/> Regular Cab | <input type="checkbox"/> 1/2 Ton | <input type="checkbox"/> Cargo | <input type="checkbox"/> 7 Passenger | <input checked="" type="checkbox"/> Diesel |
| <input type="checkbox"/> Sport Util Vch | <input type="checkbox"/> Extended Cab | <input type="checkbox"/> 3/4 Ton | <input type="checkbox"/> Sliding Door | <input type="checkbox"/> 12 Passenger | <input type="checkbox"/> 4 Cylinder |
| <input type="checkbox"/> Mid-Size | <input type="checkbox"/> Crew Cab | <input type="checkbox"/> 1 Ton | <input type="checkbox"/> Swing Door | <input type="checkbox"/> 15 Passenger | <input checked="" type="checkbox"/> 6 Cylinder |
| <input type="checkbox"/> Full-Size | <input type="checkbox"/> Cab & Chassis | <input type="checkbox"/> Class 6 | <input type="checkbox"/> Utility Body ^ | <input type="checkbox"/> Tractor/Mower | <input type="checkbox"/> 8 Cylinder |
| <input type="checkbox"/> 2 Door | <input type="checkbox"/> 2 Wheel Drive | <input type="checkbox"/> Class 7 | <input type="checkbox"/> Flat Bed ^ | <input type="checkbox"/> Dual RW | <input type="checkbox"/> 10 Cylinder |
| <input type="checkbox"/> 4 Door | <input type="checkbox"/> 4 Wheel Drive " | <input type="checkbox"/> Class 8 | <input type="checkbox"/> Dump Truck ^ | <input type="checkbox"/> Single RW | <input type="checkbox"/> Other |

Additional description for vehicles or equipment:

BUCKET TRUCK PER ATTACHED SPEC.

^u Please provide detailed justification on separate sheet.

****NOTE** If you need any additional equipment added to this order, please list all the different items. We will order everything we can as one package. This will minimize the turn around time when the new equipment comes in.**

9. What, if any, special options or accessories are required? Please check all appropriate options below and list any additional options on the lines below: i.e. lift gates, 50' telescopic boom, emergency lighting package, light-bar, 60" hydraulic rotary mower, etc. Please attach brochures if applicable:

All County vehicles are ordered with the following standard options: Air Conditioning, AM/FM Radio, Automatic Transmission, Rear Anti-Lock Brakes.

****See Next Page for the options****

For Fleet Use Only.			
Replacement Points: Maintenance-	<u>34</u>	Meter-	<u>50</u>
		Age-	<u>3.3</u>
		Total-	<u>11.7</u>
Initials	<u>[Signature]</u>	Fleet Spec #	<u>04-222</u>

MAY 27 2004

LEE COUNTY GOVERNMENT, DIVISION OF FLEET MANAGEMENT
EQUIPMENT AND VEHICLE REQUEST FORM
(PLEASE PRINT OR TYPE)

Vehicles - Cars & Light Trucks:

- | | | | |
|--|---|--|---|
| <input type="checkbox"/> Cassette | <input type="checkbox"/> Plastic Bed-Liner | <input type="checkbox"/> Arrow Board ^ | <input type="checkbox"/> Strobe Light ^ |
| <input type="checkbox"/> CD Player | <input type="checkbox"/> Spray in bed liner | <input type="checkbox"/> Power Win/Locks | <input type="checkbox"/> 4-Corner Strobes |
| <input type="checkbox"/> Tires - All Terrain | <input type="checkbox"/> Long Bed | <input type="checkbox"/> Floor - Carpet | <input type="checkbox"/> Seats - Cloth |
| <input type="checkbox"/> Tow Package | <input type="checkbox"/> Short Bed | <input type="checkbox"/> Floor - Rubber | <input type="checkbox"/> Seats - Vinyl |
| <input type="checkbox"/> Trailer Hitch Receiver | <input type="checkbox"/> Cruise Control | <input type="checkbox"/> Tool boxes ^ | <input type="checkbox"/> Tinted Windows |
| <input type="checkbox"/> Limited Slip | <input type="checkbox"/> Tilt Steering Wheel | <input type="checkbox"/> Lockable Tailgate | <input type="checkbox"/> Camper Top ^ |
| <input type="checkbox"/> Back Up Alarm | <input type="checkbox"/> Cone Holder | <input type="checkbox"/> Security Alarm | <input type="checkbox"/> Auxiliary 12-Volt Plug ^ |
| <input type="checkbox"/> Work Lights | <input type="checkbox"/> Pipe Racks ^ | <input type="checkbox"/> Water Cooler Holder | <input type="checkbox"/> Steps ^ |
| <input type="checkbox"/> Mounted Winch ^ | <input type="checkbox"/> Bulk Fuel Tank W/Pump (Diesel or Unleaded) ^ | | |
| <input type="checkbox"/> Other. Please list: _____ | | | |

Farm Tractor:

- | | | | |
|--|---|---|--|
| <input type="checkbox"/> Three spool Hyd Valve | <input type="checkbox"/> Mounted Tool Box ^ | <input type="checkbox"/> Mounted Strobe Light ^ | <input type="checkbox"/> Tinted Windows |
| <input type="checkbox"/> Front Weights | <input type="checkbox"/> Rear Weights | <input type="checkbox"/> Flashing Work Lights | <input type="checkbox"/> Water Cooler Holder |
| <input type="checkbox"/> Auxiliary 12-volt Plug ^ | <input type="checkbox"/> 4-Corner Strobe Lights | <input type="checkbox"/> Cassette Radio | <input type="checkbox"/> AM/FM Radio |
| <input type="checkbox"/> AM/FM/CD Radio | | | |
| <input type="checkbox"/> Other. Please list: _____ | | | |

Trucks:

- | | | | |
|--|--|--|---|
| <input checked="" type="checkbox"/> Mounted Tool Box | <input checked="" type="checkbox"/> Mounted Strobe Light | <input checked="" type="checkbox"/> Tinted Windows | <input type="checkbox"/> Work Lights |
| <input checked="" type="checkbox"/> 4-Corner Strobe Lights | <input type="checkbox"/> Water Cooler Holder | <input type="checkbox"/> Fenders Over Rear Tires | <input type="checkbox"/> Flashing Work Lights |
| <input type="checkbox"/> Hyd Wet Line System | <input checked="" type="checkbox"/> AM/FM Radio | <input type="checkbox"/> Cassette Radio | <input type="checkbox"/> AM/FM/CD Radio |
| <input checked="" type="checkbox"/> Air Horns ^ | <input checked="" type="checkbox"/> Back Up Alarm | <input checked="" type="checkbox"/> Auxiliary 12-Volt Plug ^ | |
| <input type="checkbox"/> Other. Please list: _____ | | | |

10. What will be the primary use of the new equipment or vehicle? TRAFFIC SIGNAL
MAINTENANCE & REPAIR

^ Specify Dimensions, Makes, Models, or Locations PER ATTACHED SPECS

VERA LIT - [unclear]
 VLT-5000

MAY 27 2004

104
6904382

LEE COUNTY GOVERNMENT, DIVISION OF FLEET MANAGEMENT EQUIPMENT AND VEHICLE REQUEST FORM

(PLEASE PRINT OR TYPE)

11. Funding source:

Vehicle Replacement Fund

Capital, Please Specify Account String PD59104175006430 - \$

Other, Please Specify Account String JB5191059401.349000.9005 - \$27000.00

If needed, please provide additional account strings: _____

****Please Note**** Allow enough money to cover the cost of Parts, repair and service manuals or CDs.

12. We are authorizing a purchase not to exceed: \$ _____

***Please provide Account String for Maintenance, Fuel, Repairs, etc. if different than the vehicle or equipment being replaced: _____

Fixed asset custodian name: _____ Custodian number: _____

Area number: _____ Site/Building code: _____

Joe Foose 7/1/04 Mike Borens 7/1/04
REQUESTED BY DATE SUPERVISOR DATE

Option 1: QUOTES AND REQUISITION. This option authorizes Fleet Management to obtain quotes and authorizes Fleet Management to issue a requisition using the account string(s) provided above.

Option 2: VEHICLE REPLACEMENT FUND PURCHASES. This option authorizes Fleet Management to obtain quotes and authorizes Fleet Management to purchase the equipment or vehicle using motor pool funds (formerly known as surcharge funds).

Ph. O. Lewis 7/1/04 _____ _____
DEPARTMENT DIRECTOR DATE COUNTY MANAGER / DESIGNEE DATE

Rx

SUBMIT THIS COMPLETED FORM TO FLEET MANAGEMENT

Don 10/18/04 Marilyn Rawlings 10/18/04
OPERATION'S MANAGER DATE FLEET MANAGER DATE

For Fleet Use Only.

Price verification against State Contract and Sheriff's Contract.

Going to the board for approval to purchase off of GSA contract.

Vendors Price \$ _____ State Contract \$ _____ Sheriff's Contract \$ _____

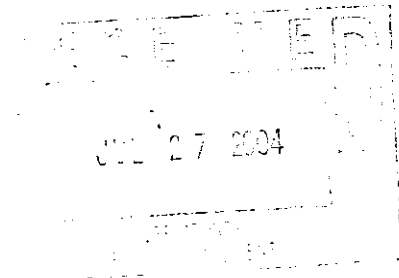

**EQUIPMENT/VEHICLE REQUEST FORM
CHECKLIST**

1. Check for correct name of Department/Division and for correct Department/Division number.
2. Check and list the Replacement Points in FASTER.
3. Double check for specifications, Options and Accessories. *see attached spec.*
4. Check Funding Source, double check the account strings for accuracy. Verify with department if necessary.
5. It is crucial to make sure the **not to exceed \$** is complete. If the purchase is going to exceed the dollar amount, ask the requestor to send us an e-mail, acknowledging and approving a new not to exceed purchase amount.
6. **Option 1** Quote and Requisition or **Option 2** Vehicle Replacement Fund Purchases must be checked.
7. Signatures Are Required.
 - a. Jim Lavender must sign for all Public Works requests.
 - b. John Yarbrough must sign for all Parks requests.
 - c. County Manager level authorization must be on all new (non-replacement) equipment requests.
8. Staple this checklist to the back of the Equipment and Vehicle Request form.
9. Give Request package to Danny.

Karen Shilling Date 7/27/04
Checklist Completed By

FACSIMILE

DATE: October 6, 2004

PAGE 1 OF 2

TO: Joe Foose
 Lee County - DOT
 Ph: (239) 694-7600
 Fax: (239) 694-1332



SUBJECT: Quote # D-6176, Revision 3
 GSA Contract # GS-30F-1024H

<u>Model</u>	<u>Description</u>	<u>Price</u>
VST-5000I	VERSALIFT VST-5000-I, insulated 50 ft. (15.2 m) telescopic aerial platform lift, 55 ft. (16.8 m) working height including the following items:	\$99,567.00

33,000 lb. GVWR International 4300 4x2 cab and chassis with 84" cab to axle, six (6) speed manual transmission, DT466 diesel engine, air conditioning, and AM/FM radio.
 132" steel line body with standard compartments, curbside access, treadplate tops and floors, and 24" tailshelf.

Standard platform capacity of 600 lbs. (272 kg).

Platform mounted full pressure Unitrol single-stick control including safety trigger, emergency stop, and hydraulic platform rotator with tilt for cleanout or rescue.

Engine start/stop from platform and lower controls.

Continuous rotation with slip rings.

Six gpm (22.7 lpm) open center hydraulic system with a 2250 psi (158 kg/cm²) operating pressure.

Side mounted telescopic upper boom allows low stowing of platform. Fiberglass inner boom and patented ELECTROGARD provide insulation gap fully retracted meeting ANSI A92.2-2001 requirements for Category C, 46KV and below.

Chassis insulating system (fiberglass lower boom insert) providing 24 in. (0.61 m) insulation gap and including accommodations to bridge insulation gap for testing per ANSI 92.2-2001.

ELECTROGARD and inner boom finished with white urethane paint over a white gel coat.

Non-lube bearings used throughout.

One set of hydraulic tool outlets at platform. Quick disconnect fittings are not included.

Six (6) inch taller tubular pedestal including pedestal mounted A-frame outriggers with pivot feet, two control valves, and a selector valve.

Auxiliary H-frame outriggers.

Integral reservoir with a 25-gallon (94.5 l) capacity and dual sight gauges.

Closed heavy-duty one-step 24 in. X 48 in. X 42 in. (0.61m X 1.22m X 1.07m) fiberglass platform with liner and cover.

180 degree platform rotator.

Master/slave hydraulic leveling with upper and lower control to tilt for cleanout or rescue.

Upper boom storage cradle with ratchet type tie down strap.

Throttle control.

Tubular rubber platform support.

Mounting hardware.

Unit painted standard white.

Safety belts and lanyards.

Three operators manuals and service manuals.

ANSI 92.2-2001 data plate.

D-6176, Revision 3

Page 2 of 2

REQUESTED OPTIONS:

36" x 80" aluminum platform with door in lieu of the 24" x 48" fiberglass platform with liner and cover	\$1,235.00
FULL HYDRAULIC JIB AND WINCH	\$4,620.00
3000W INVERTER	\$3,000.00
PAINT BOOMS OMAHA ORANGE	\$635.00

STANDARD GSA OPTIONS: Option prices per GSA contract GS-30F-1024H in addition to above price. Any options not listed are special options, consult factory for pricing and delivery schedule.

EMERGENCY POWER	\$406.00
INTERNATIONAL ALLISON 3500 5 SPEED AUTOMATIC TRANSMISSION	\$6,018.00
STROBES (4)	\$836.00
BACK UP ALARM	\$197.00
OUTRIGGER BOOM INTERLOCK, MAIN & AUX.	\$1,365.00
HYD. TOOL POWER AT REAR	\$317.00
BUMPER w/PINTLE & PLUG	\$730.00
BED ACCESS STEP AND GRAB HANDLE	\$335.00

TOTAL PRICE: \$119,261.00

TRADE IN:

97 International 4700 with VST5000 and utility body. (Appx. 90,000 miles) **\$ -8,000.00**

COMPLETE TOTAL PRICE F.O.B. LEE COUNTY, FLORIDA: \$111,261.00

TERMS: Net 30 days.

SHIPMENT: Approximately 150-180 days after date of order or 60 days after receipt of chassis, whichever is later.

Please let us know if you have any questions.

Best Regards,

Stan Tomchesson, Sales Coordinator

Phone: (254) 399-2167, E-mail: stant@timemfg.com

- message
- VST50001 6176DR1.doc
- VST50127-...
- Mime.822

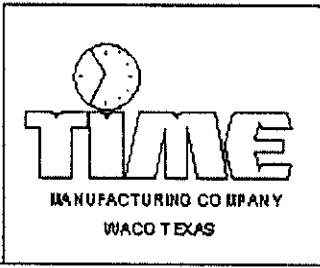
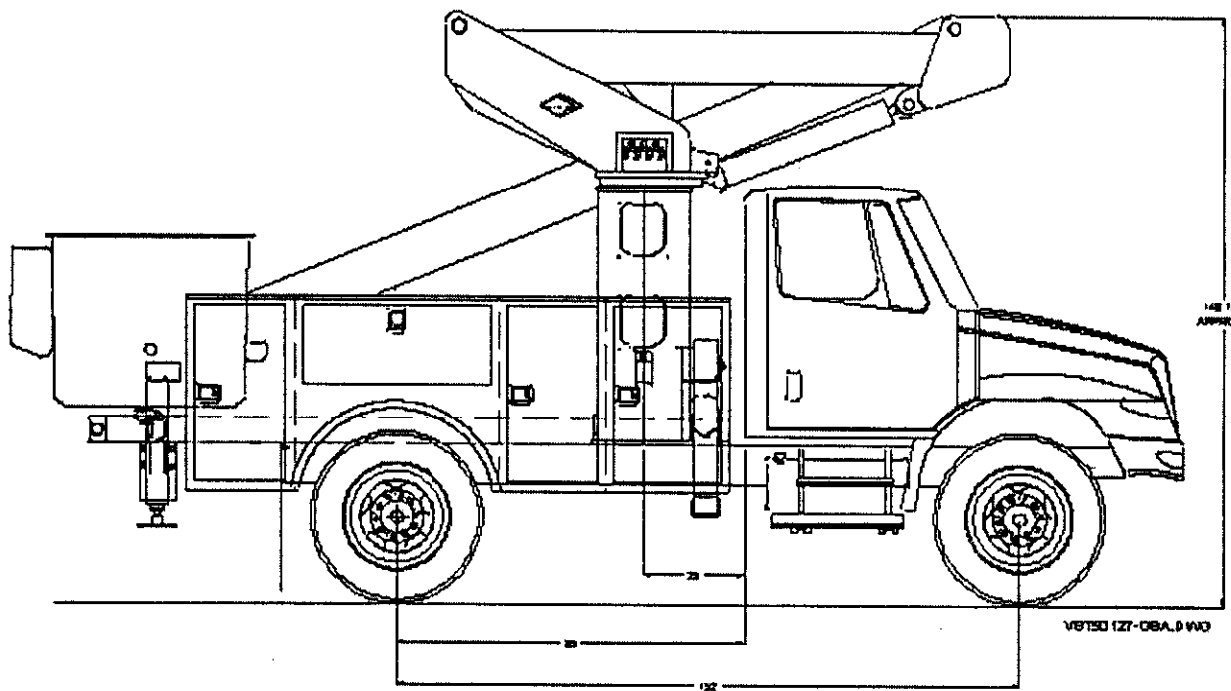

CHASSIS:	2003 INTERNATIONAL	MO DEL:	4300
BODY TYPE:	LINE	STYLE:	132" STEEL
LIFT MO DEL:	VST-5000 H	DRAWN BY:	ATB
DATE:	5-27-03	DWG. NO.:	VST50127



From a small simple telescopic one-man lift, built to meet the needs of a small independent telephone company, the VERSALIFT product line has expanded to include over 30 models ranging in height from 29" to 65". The Versalift line consists of articulated overcenter and articulated non-overcenter aerial lifts, telescopic and telescopic/articulated aerial devices, as well as a complete line of digger derricks for pole line construction.

If you're looking for an equipment manufacturer that will be with you long after you've signed the deal, it's TIME.

Since 1965, TIME Manufacturing has been reaching higher, pushing farther and expanding our product lines to provide a complete selection of truck-mounted aerial lifts and digger derricks to serve a variety of industrial, commercial and governmental needs.

As makers of the Versalift and Condor lines, TIME has a proven record of not only selling you the right equipment, but staying with you for the long haul.

VST-5000-I

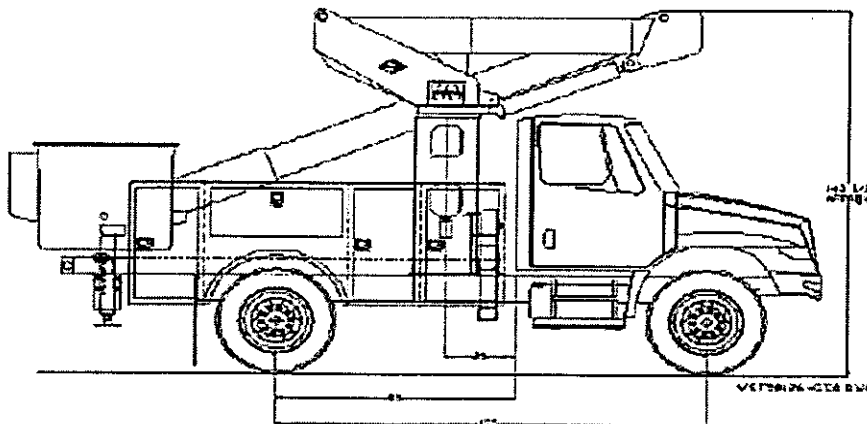

Versalift Model No.: VST-5000-I

Description: Insulated, side mounted 50 ft. (15.2 m) telescopic aerial platform lift, including 600 lb. platform capacity.

Chassis Model: INTERNATIONAL 4300 4X2

Description: 33,000 lb. GVWR cab and chassis with 84 inch cab to axle, six (6) speed manual transmission, DT466 diesel engine, AM/FM radio, and air conditioning.

Body Model: STEEL SERVICE BODY

Description: 132 inch steel line body with standard compartments, treadplate tops and floor, and 24 inch tailshelf.

Installed Items: INSTALLATION

Description: Install Versalift VST-5000-I and line body on chassis. Installation also includes PTO and pump, pedestal mounted A-frame and auxiliary H-frame outriggers, and painting body to match chassis.

COMPLETE TOTAL PRICE F.O.B. DESTINATION: \$ 99,587.00

[Return to Top](#)

VST-5000-I Standard Options

EMERGENCY POWER \$406.00

INTERNATIONAL/AUTOMATIC TRANSMISSION \$6,018.00

CENTRAL LOCKING \$269.00

CHOCK BLOCK HOLDERS \$153.80

COMPARTMENT LIGHTING \$695.20

FLOOD LIGHTS \$616.00

STROBE \$418.00

BACK UP ALARM \$197.00

OUTRIGGER BOOM INTERLOCK, MAIN & AUX. \$1,365.00

HYD. TOOL POWER AT PLATFORM \$72.00 (Requires two speed throttle)

HYD. TOOL POWER AT REAR \$317.00 (Requires two speed throttle)

PINTLE AND PLUG \$730.00

BUMPER w/PINTLE & PLUG \$730.00

BED ACCESS STEP AND GRAB HANDLE \$335.00